

Product packaging logic diagram

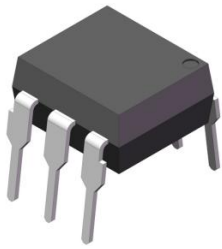

DIP6

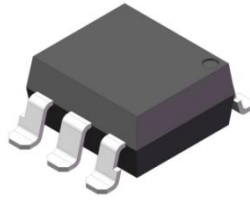

SMD6

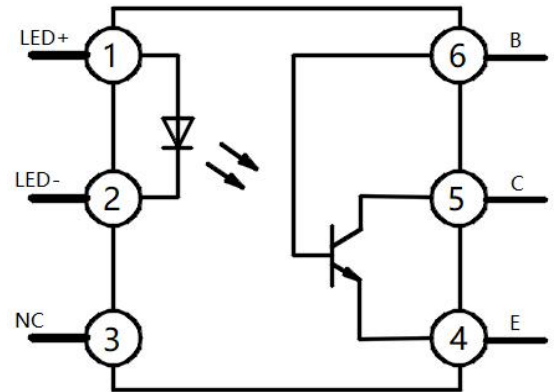

Pin Configuration

Features

- Current transfer ratio (CTR: $\geq 20\%$ at $I_F = 10\text{mA}$, $V_{CE} = 10\text{V}$)
- High isolation voltage between input and output ($V_{iso} = 5000\text{Vrms}$)
- Operating Temperature: $-55^\circ\text{C} \sim 100^\circ\text{C}$
- Environmentally friendly products, compliant with CQC, UL, and VDE requirements

Mechanical Data

- Case: DIP6, SMD6
- Molding Compound: UL Flammability Classification Rating 94V-0
- Terminals: Matte tin-plated leads; solder ability-per MIL-STD-202, Method 208

Applications

- It is widely used in the feedback control loop of switching power supply and the isolation between the main circuit and the control circuit, ensuring the stability of the output voltage and quickly transmitting the fault signal to trigger the protection mechanism in the case of overload or short circuit.
- In applications such as PLCs (Programmable Logic Controllers), motor drives, and sensor interfaces, it is used for signal isolation to prevent high-voltage noise from interfering with low-voltage control logic.
- For signal isolation in serial communication interfaces (e.g., RS-232,) to improve anti-interference capability.
- Consumer electronics: household appliances, smart home devices (smart lighting, smart sockets), computers and peripherals (printers, monitors), etc.
- Lighting control: AC transistor optocoupler is suitable for dimming control, smart switching, and wireless control, supporting AC input.



Ordering Information

XL CNY17-2 (X) (X) - (U) (N) (Y)
 ① ② ③ ④ ⑤ ⑥ ⑦

- ① Brand(XL)
- ② Product series(CNY17-2)
- ③ Package type(DIP6:None, SMD6:S)
- ④ Halogen option(None :Halogen free)
- ⑤ Lead frame (None: Copper)
- ⑥ Customer option 1 (0-9 or A-Z or none)
- ⑦ Customer option 2 (0-9 or A-Z or none)

Part Number	Package	Shipping Quantity	Marking Code
XLCNY17-2	DIP6	65pcs / Tube	XLCNY17-2
XLCNY17-2S	SMD6	1000pcs / Tape & Reel	XLCNY17-2

Marking Information

- " XL" denotes brand.
- " CNY17-2" denotes Product series.
- " Y" denotes Year : A(2024), B(2025), C(2026)
- " WW" denotes Week' s number .
- " N" denotes the day of Week.



Maximum Ratings (@ T_A = 25°C unless otherwise specified)

Parameter		Symbol	Value	Unit
Input	Forward Current	I _F	60	mA
	Forward Peak Current*1	I _{FP}	1	A
	Reverse Voltage	V _R	6	V
	Power Dissipation	P _D	100	mW
Output	Collector Power Dissipation	P _C	300	mW
	Collected Current	I _C	100	mA
	Collector-Base Voltage	V _{CB0}	70	V
	Collector-Emitter Voltage	V _{CEO}	30	V
	Eemitter- Collector Voltage	V _{ECO}	7	V

Thermal Characteristics

Parameter	Symbol	Value	Unit
Total Power Dissipation	P _{TOT}	350	mW
Isolation Voltage *2	V _{ISO}	5000	V _{rms}
Operating Temperature	T _{OPR}	-55 ~ +100	°C
Storage Temperature Range	T _{STG}	-55 ~ +125	°C
Soldering Temperature *3	T _{SOL}	260	°C

Notes:

1. Pulse width ≤ 1μs, Duty ratio: 0.001
2. 40 to 60% RH, AC for 1 minute. At this time, pins 1, 2 & 3 are shorted, and pins 4, 5 & 6 are shorted together.
3. For 10 seconds

Electrical Characteristics (@ T_A = 25°C unless otherwise specified)

Parameter		Symbol	Test Condition	Min.	Typ.	Max.	Unit
Input	Forward Voltage	V _F	I _F = 10mA	-	1.2	1.5	V
	Reverse Current	I _R	V _R = 3V	-	-	10	μA
	Input Capacitance	C _t	V = 0V, f = 1kHz	-	50	-	pF
Output	Collector Dark Current	I _{CEO}	V _{CE} = 10V	-	-	50	nA
	Collector-Base Breakdown Voltage	B _V C _B O	I _B = 0.1mA, I _F = 0	70	-	-	V
	Collector-Emitter Breakdown Voltage	B _V C _E O	I _C = 0.1mA, I _F = 0	30	-	-	V
	Emitter-Collector Breakdown Voltage	B _V E _C O	I _E = 0.01mA, I _F = 0	7	-	-	V
Transfer Characteristics	Current Transfer Ratio	CTR	I _F = 10mA, V _{CE} = 10V	20	-	-	%
	Collector-Emitter Saturation Voltage	V _{CE(sat)}	I _F = 50mA, I _C = 2mA	-	-	0.5	V
	Isolation Resistance	R _{ISO}	DC500V, 40~60%R.H.	5*10 ¹⁰	10 ¹¹	-	Ω
	Isolation Capacitance	C _f	V = 0, f = 1MHz	-	1	2.5	pF
	Response Time (Rise)	T _r	V _{CE} = 10V I _C = 2mA, R _L = 100Ω	-	3	10	μs
	Response Time (Fall)	T _f		-	3	10	μs

Ratings and Characteristics Curves (@ $T_A = 25^\circ\text{C}$ unless otherwise specified)

Fig.1 Forward Current vs. Forward Voltage

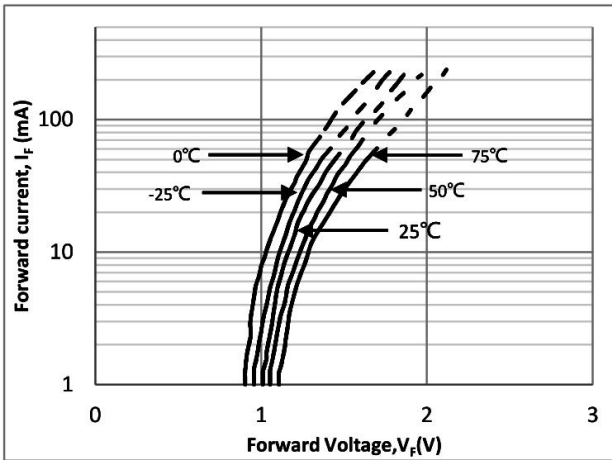

Fig.2 Collector Current vs. Collector-emitter Voltage

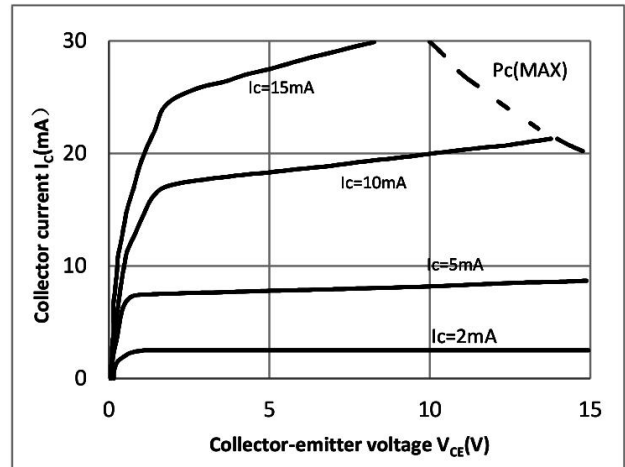

Fig.3 Forward Current vs. Forward Voltage

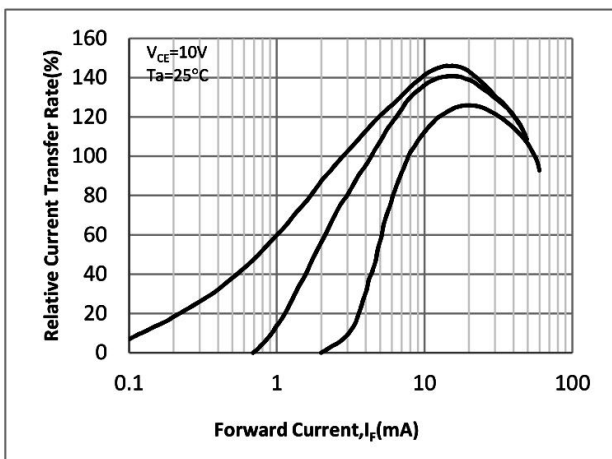

Fig.4 Collector-emitter Saturation Voltage vs. Forward Current

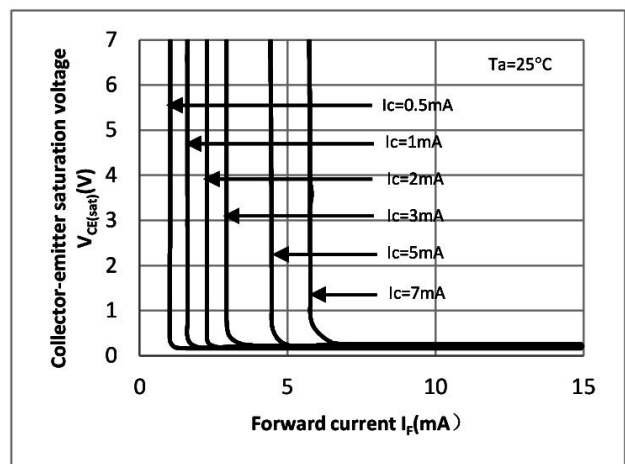

Fig.5 Collector Dark Current vs. Ambient Temperature

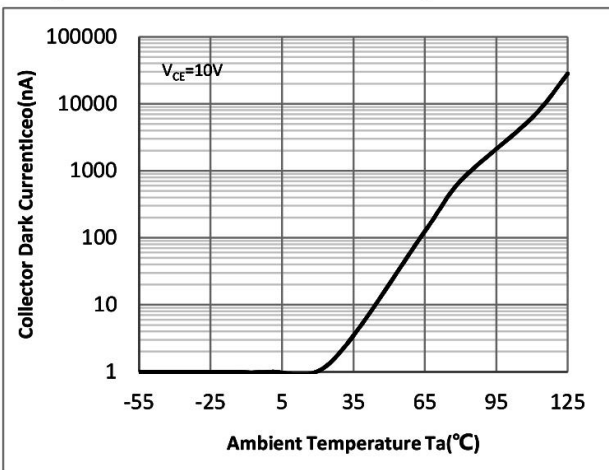
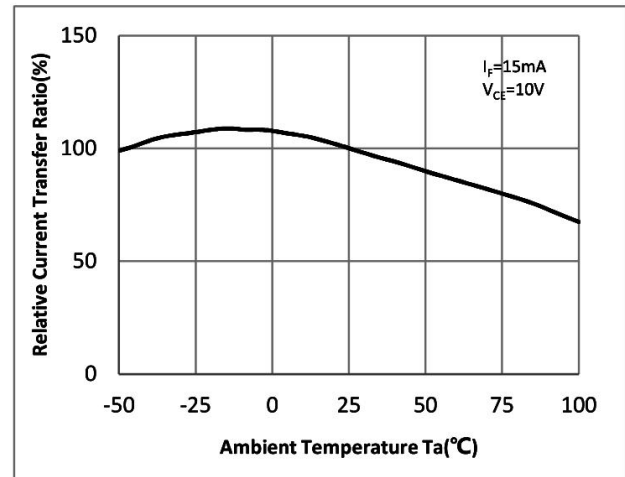

Fig.6 Relative Current Transfer Ratio vs. Ambient Temperature



Ratings and Characteristics Curves (@ $T_A = 25^\circ\text{C}$ unless otherwise specified)

Fig.7 Response Time vs. Load Resistance

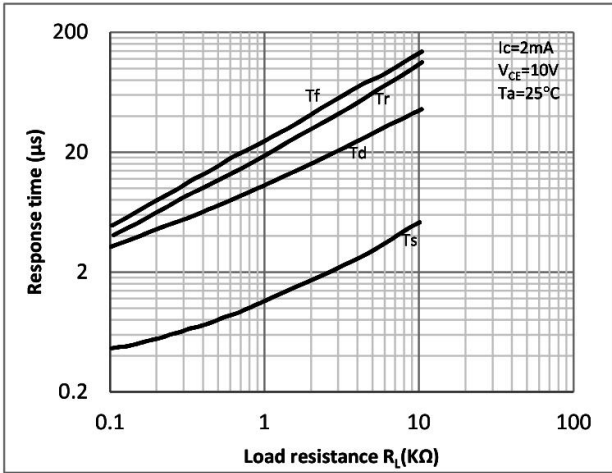
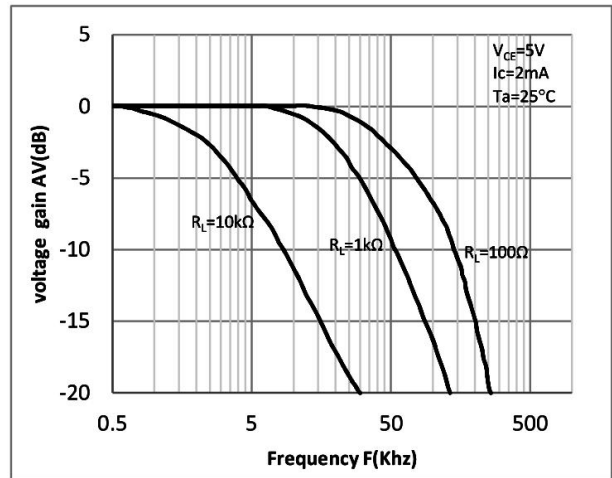
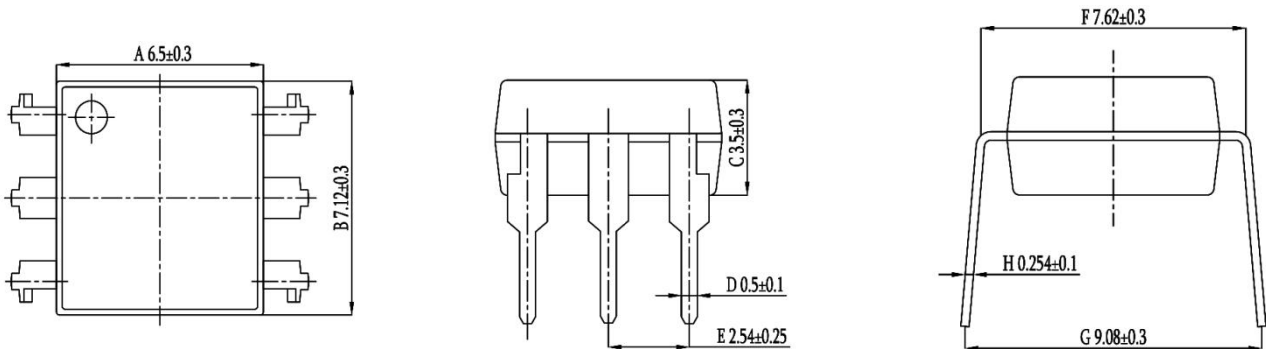

Fig.8 Frequency Response



Package Outline Dimensions (unit: mm)

DIP6



SMD6

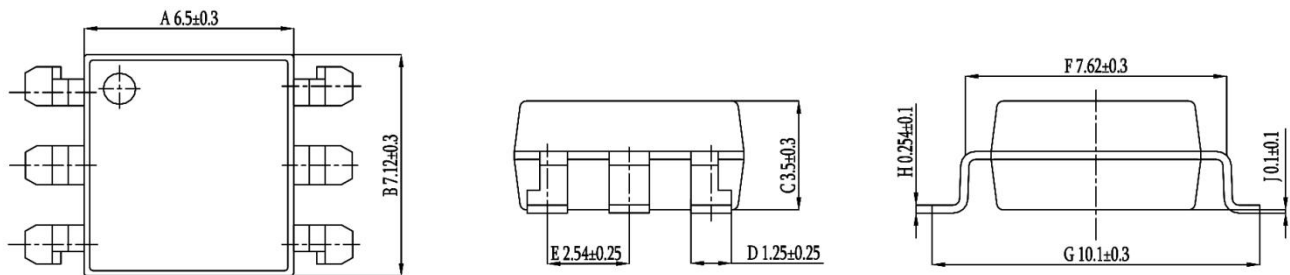

SOLDERING FOOTPRINT (unit: mm)

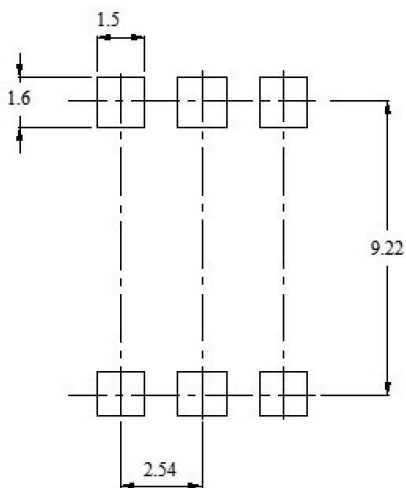

Reflow soldering

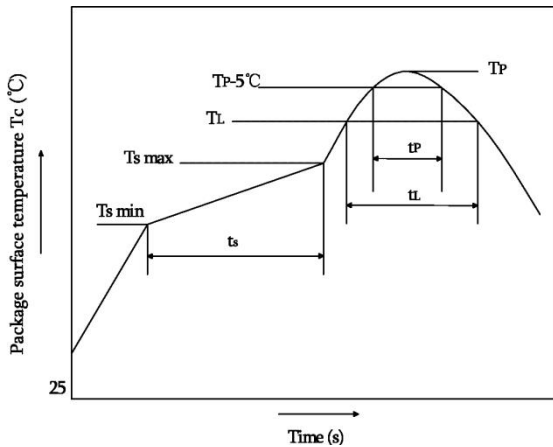

	Symbol	Min	Max	Unit
Preheat temperayure	Ts	150	200	°C
Preheat time	ts	60	120	s
Ramp-up ratea(TL to TP)	-	-	3	°C/s
Liquidus temperature	TL	217		°C
Time above TL	tL	60	150	s
Peak temperature	Tp	-	260	°C
Time during which Tc is between (TP-5) and TP	tp	-	30	s
Ramp-down rate(TP to TL)	-	-	6	°C/s

Note:

Reflow soldering is recommended at the temperatures and times shown, no more than three times.

Wave soldering

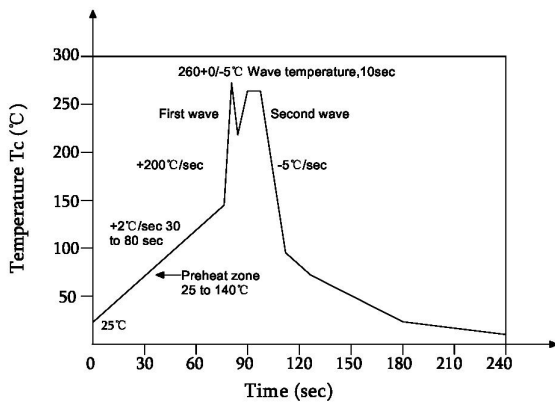

Profile feature	
Average ramp-up rate	~200°C/s
Heating rate during preheat	1°C/s to 2°C/s typical; 4°C/s maximum
Final preheat temperature Ts	~130°C
Preheat time (25°C to Ts)	>60s
Peak temperature Tp	260°C
Time within peak temperature tp	10s
Ramp-down rate	5°C/s maximum

Soldering with hand soldering iron

- A. Hand soldering iron is only used for product rework or sample testing.
- B. Hand soldering iron requirements: Temperature: 360 °C+5°C within 3s.

Packing

Package Type	Packing Form	Quantity per Tube & Reel	Quantity per Box	Quantity per Carton	Antistatic Bag Specification	Box Specification	Carton Specification	Note
DIP6	Tube(500mm)	65pcs/tube	50 tubes /box	10 boxes /ctn	190*670mm	520*105*50mm	545*372*235mm	Straight insert type material tube
SMD6	Reel(φ330mm)	1000 pcs/reel	2 redls/box	10 boxes /ctn	380*420mm	350*340*60mm	365*330*370mm	Guard band 200mm/min.

■ Summary table

■ DIP6 (Tube)

Qty/ tube: 65pcs. Qty/box: 3250pcs.

Qty/ctn: 32500pcs.

Schematic: (unit:mm)

■ SMD6 (Reel)

Qty/reel: 1000pcs. Qty/box: 2000pcs.

Qty/ctn: 20000pcs.

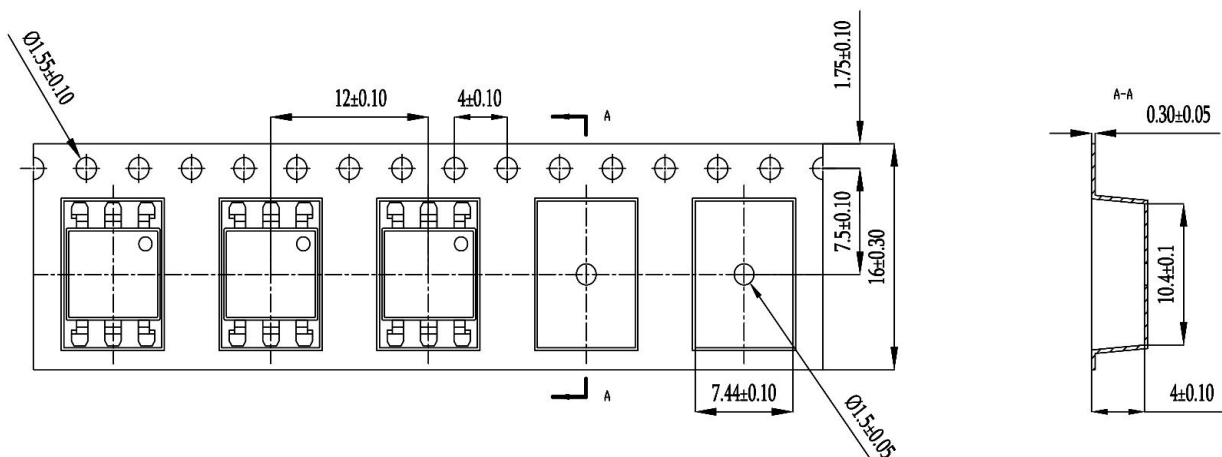

Attention

- XINGLIGHT implements dynamic technical updates. Specifications are subject to change. Refer to the official website for the latest version.
- Users must strictly adhere to specified conditions. Failures caused by misuse (overload, high temperature, incompatible circuits) are excluded from warranty.
- Contact technical support for customized validation in critical applications (medical devices, industrial control).
- This document is valid until Dec 31, 2026. Updates will be notified on the official website.
- For further clarification on technical specifications or application solutions, please contact us through official channels.