

#### Product packaging logic diagram

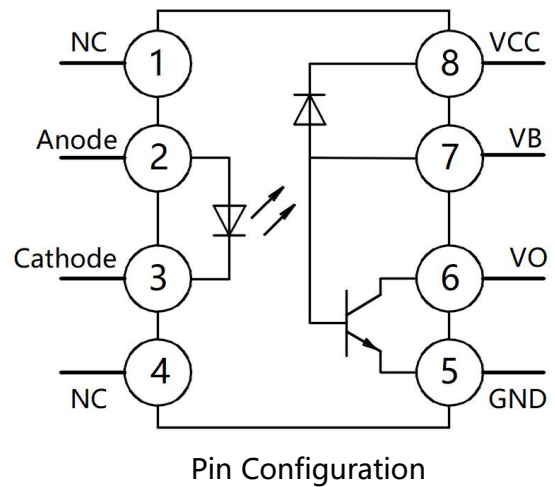
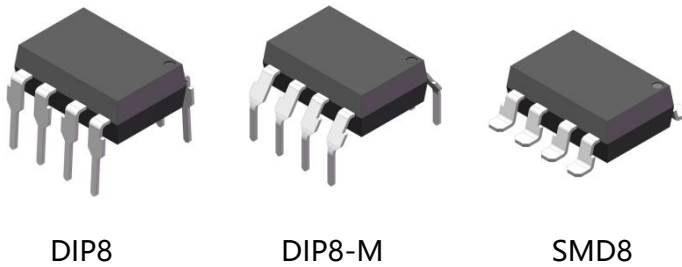

#### Features

- Very high speed: 1 MBit / s
- High isolation voltage between input and output ( $V_{iso} = 5000V_{rms}$ )
- Operating Temperature:  $-40^{\circ}C \sim 100^{\circ}C$
- Open-Collector Output
- Environmentally friendly products, compliant with CQC, UL, and VDE requirements

#### Mechanical Data

- Case: DIP8、DIP8-M、SMD8
- Molding Compound: UL Flammability Classification Rating 94V-0
- Terminals: Matte tin-plated leads; solder ability-per MIL-STD-202, Method 208

#### Applications

- Widely used in communications and networking, industrial automation and control, motor drive and energy management, medical equipment, and automotive electronics fields.
- Communications and Networking: Fiber optic communication, data center.
- Industrial Automation and Control: PLC and frequency converter, Servo drive system, Industrial robot.
- Motor Drive and Energy Management: Motor control, Motor protection, Power electronics, Consumer Electronics.
- Emerging Technology Fields: Intelligent Transportation System, Medical equipment, Automatic production line.
- Automotive Electronics: In-vehicle Network System, Battery Management System (BMS), EV Charging Station.



### Ordering Information

XL    6N13X    (X)    (X)    (X)    -    (U)    (N)    (Y)  
 ①        ②        ③        ④        ⑤        ⑥        ⑦        ⑧

- ① Brand (XL)
- ② Product series (6N135, 6N136)
- ③ Package type (None: DIP8, DIP8-M, SMD8)
- ④ Halogen option (None : Halogen free)
- ⑤ CTR Bank (None)
- ⑥ Lead frame (None: Copper)
- ⑦ Customer option 1 (0-9 or A- Z or none)
- ⑧ Customer option 2 (0-9 or A- Z or none)

Part Number	Package	Shipping Quantity	Marking Code
XL6N13X <sup>1</sup>	DIP8	45pcs / Tube	XL6N13X <sup>1</sup>
XL6N13X <sup>1</sup> M	DIP8-M	45pcs / Tube	XL6N13X <sup>1</sup>
XL6N13X <sup>1</sup> S	SMD8	1000pcs / Tape & Reel	XL6N13X <sup>1</sup>

Notes 1: X denotes product series: 5, 6

### Marking Information

- " XL " denotes brand
- " 6N13X " denotes product series: 5, 6.
- " Y " denotes Year : A(2024), B(2025), C(2026)
- " WW " denotes Week' s number
- " N " denotes the day of Week.

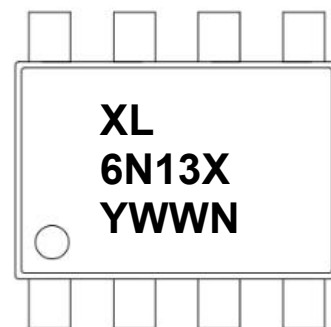

## XL6N135,XL6N136

### Maximum Ratings (@ T<sub>A</sub> = 25°C unless otherwise specified)

Parameter		Symbol	Value	Unit
Input	DC/Average forward input current	I <sub>F (avg)</sub>	25	mA
	Peak forward input current (50% duty cycle, 1 ms p.w.)	I <sub>F (pk)</sub>	50	mA
	Reverse Voltage	V <sub>R</sub>	5	V
	Peak transient input current	I <sub>F(trans)</sub>	1	A
	Power Dissipation	P <sub>I</sub>	45	mW
Output	Supply Voltage	V <sub>CC</sub>	-0.5~30	V
	Output Current	I <sub>O</sub>	8	mA
	Peak output current	I <sub>O(pk)</sub>	16	mA
	Output power dissipation	P <sub>O</sub>	100	mW
	Output Voltage	V <sub>O</sub>	-0.5~20	V
	Emitter-base reverse voltage	V <sub>EBR</sub>	5	V
	Base current	I <sub>B</sub>	5	mA

### Thermal Characteristics

Parameter	Symbol	Value	Unit
Isolation Voltage <sup>*2</sup>	V <sub>ISO</sub>	5000	V <sub>rms</sub>
Operating Temperature	T <sub>OPR</sub>	-40 ~ +100	°C
Storage Temperature Range	T <sub>STG</sub>	-55 ~ +125	°C
Soldering Temperature <sup>*3</sup>	T <sub>SOL</sub>	260	°C

#### Notes:

1. Pulse width ≤ 1μs, 300 pps
2. 40 to 60% RH, AC for 1 minute
3. For 10 seconds

## XL6N135, XL6N136

### Electrical Characteristics (@ T<sub>A</sub> = 25°C unless otherwise specified)

Parameter		Symbol	Test Condition	Min.	Typ.	Max.	Unit	
Input	Forward Voltage	V <sub>F</sub>	I <sub>F</sub> = 16mA	-	1.45	1.7	V	
	Reverse Breakdown Voltage	BV <sub>R</sub>	I <sub>R</sub> =10μA	5	20	-	V	
	Diode Temperature Coefficient	ΔV <sub>F</sub> /ΔT <sub>A</sub>	I <sub>F</sub> =16mA	-	-1.6	-	mV/°C	
Output	High Level Supply Current	I <sub>CCH</sub>	V <sub>CC</sub> =15V, I <sub>F</sub> =0mA V <sub>O</sub> =Open	-	-	1	μA	
			T <sub>A</sub> =0~70°C	-	-	2	μA	
	Low Level Supply Current	I <sub>CCL</sub>	V <sub>CC</sub> =15V, I <sub>F</sub> =16mA, V <sub>O</sub> =Open	-	50	200	μA	
Transfer Characteristics	High Level Output Current	I <sub>OH</sub>	V <sub>CC</sub> =5.5V, V <sub>O</sub> =5.5V I <sub>F</sub> = 0mA	-	0.001	0.5	μA	
			V <sub>CC</sub> =15V, V <sub>O</sub> =15V I <sub>F</sub> = 0mA	-	0.005	1		
			V <sub>CC</sub> =15V, V <sub>O</sub> =15V T <sub>A</sub> =0~70°C	-	-	50		
	Low Level Output Voltage	V <sub>OL</sub>	6N135	V <sub>CC</sub> =4.5V, I <sub>F</sub> =16mA I <sub>O</sub> =1.1mA	-	0.1	0.4	V
			6N136	V <sub>CC</sub> =4.5V, I <sub>F</sub> =16mA I <sub>O</sub> =3mA	-	0.1	0.4	V
	Current Transfer ratio	CTR	6N135	V <sub>CC</sub> =4.5V, I <sub>F</sub> =16mA	7	18	50	%
			6N136	V <sub>O</sub> =0.4V	19	24	50	
	Isolation Voltage	V <sub>ISO</sub>		R <sub>H</sub> <50%, T <sub>A</sub> =25°C , I <sub>I-O</sub> ≤50μA	5000	-	-	V <sub>RMS</sub>
	Isolation Resistance	R <sub>IO</sub>		V <sub>IO</sub> = 500V	-	1×10 <sup>12</sup>	-	Ω
Floating Capacitance	C <sub>IO</sub>		f = 1MHz	-	0.6	-	pF	

### XL6N135,XL6N136

#### Switching Characteristics (@ $T_A = -40^{\circ}\text{C} \sim 85^{\circ}\text{C}$ , $V_{CC} = 5\text{V}$ , $I_F = 7.5\text{mA}$ , unless otherwise specified)

Parameter	Symbol	Test Condition		Min.	Typ.	Max.	Unit
Propagation Delay Time to Output HIGH Level	$T_{PLH}$	6N135	$I_F = 16\text{ mA}$ , $R_L = 4.1\text{K}\Omega$	-	1300	1500	ns
		6N136	$I_F = 16\text{ mA}$ , $R_L = 1.9\text{K}\Omega$	-	600	800	
Propagation Delay Time to Output Low Level	$T_{PHL}$	6N135	$I_F = 16\text{ mA}$ , $R_L = 4.1\text{K}\Omega$	-	200	1500	ns
		6N136	$I_F = 16\text{ mA}$ , $R_L = 1.9\text{K}\Omega$	-	200	800	
Common Mode Transient Immunity (at Output HIGH Level)	$ CM_H $	6N135	$R_L = 4.1\text{K}\Omega$	1000	-	-	$\text{V}/\mu\text{s}$
		6N136	$R_L = 1.9\text{K}\Omega$				
Common Mode Transient Immunity (at Output LOW Level)	$ CM_L $	6N135	$R_L = 4.1\text{K}\Omega$	1000	-	-	$\text{V}/\mu\text{s}$
		6N136	$R_L = 1.9\text{K}\Omega$				

### Ratings and Characteristics Curves (@ $T_A = 25^\circ\text{C}$ unless otherwise specified)

Fig.1 Normalized CTR vs. Input current

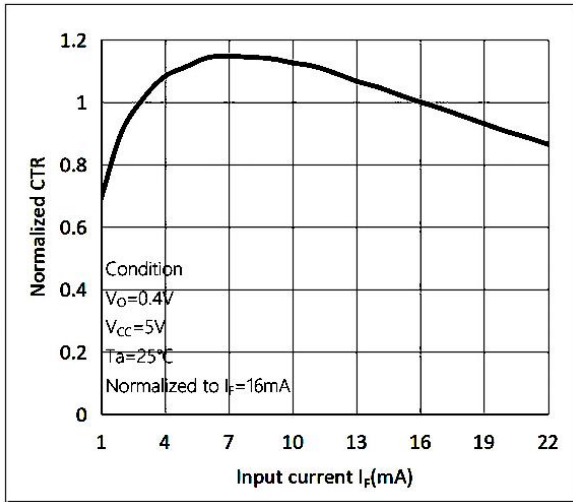

Fig.2 Normalized CTR vs. Ambient temperature

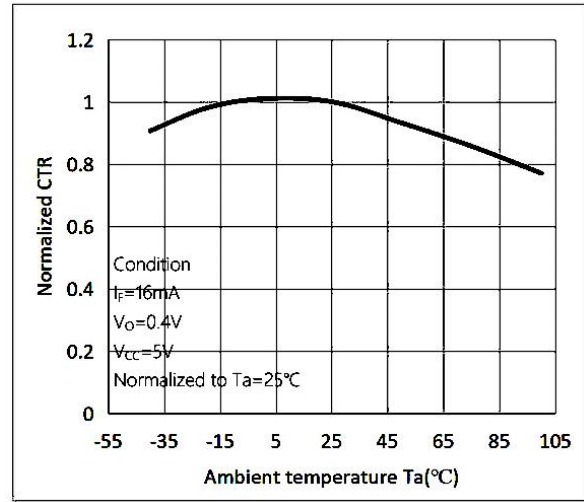

Fig.3 Output current vs. Output voltage

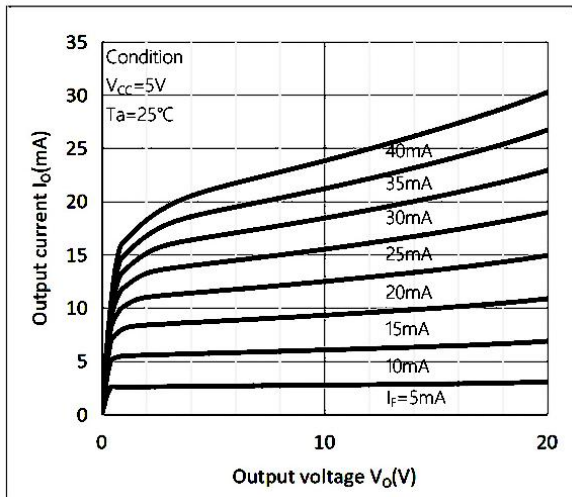

Fig.4 High level output voltage vs. Ambient temperature

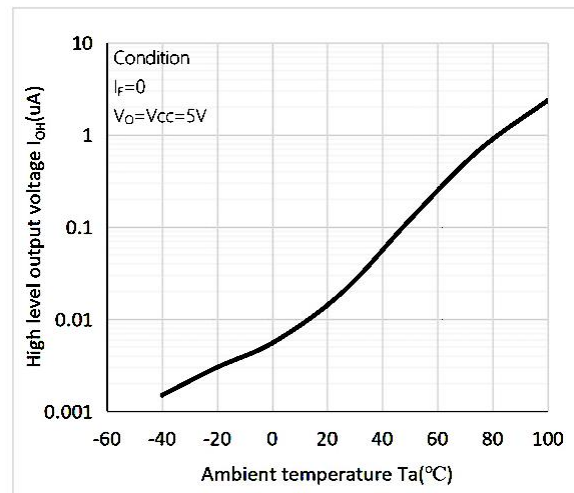

Fig.5 Propagation Delay Time vs. Ambient temperature

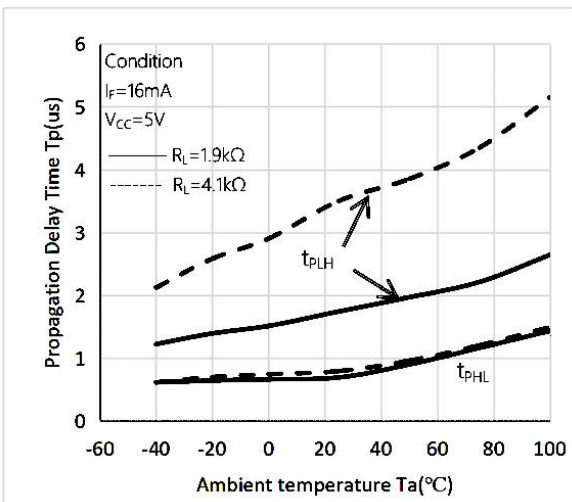
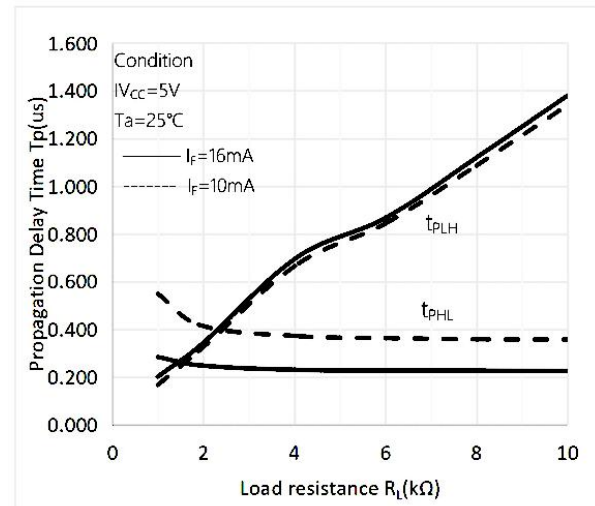

Fig.6 Propagation Delay Time vs. Load resistance



### XL6N135, XL6N136

#### Ratings and Characteristics Curves (@ $T_A = 25^\circ\text{C}$ unless otherwise specified)

Fig.7 Switching Time Test Circuit

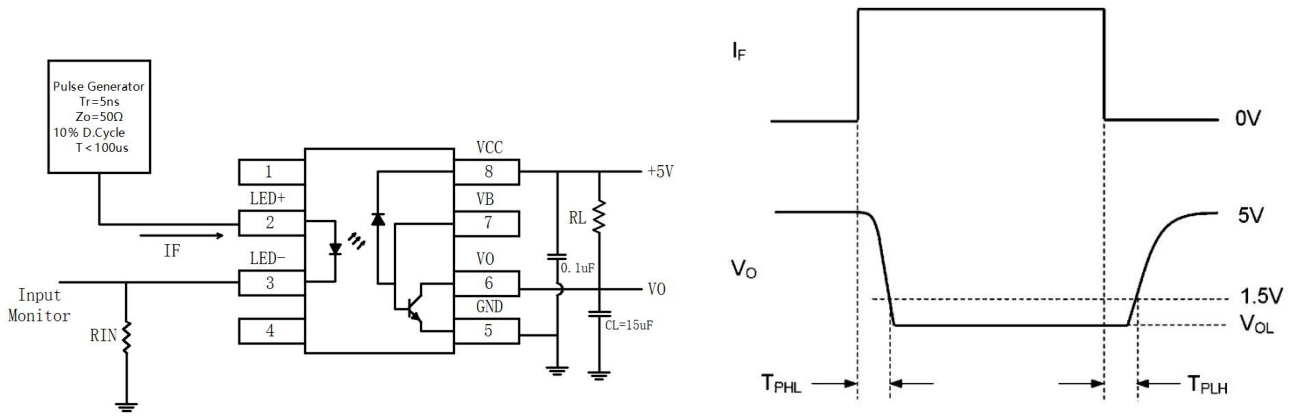
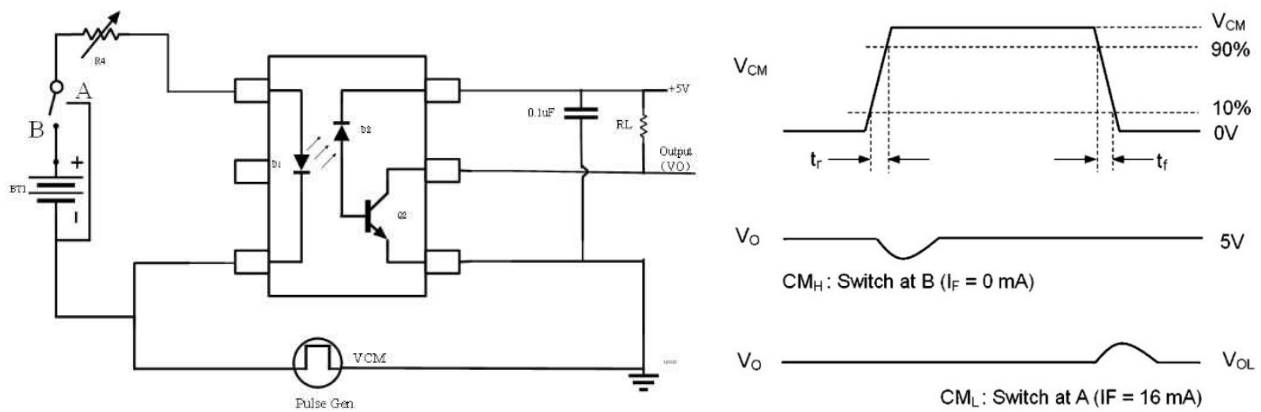

Fig.8 Test Circuit for Common Mode Transient Immunity



### XL6N135, XL6N136

#### Package Outline Dimensions (unit: mm)

##### DIP8

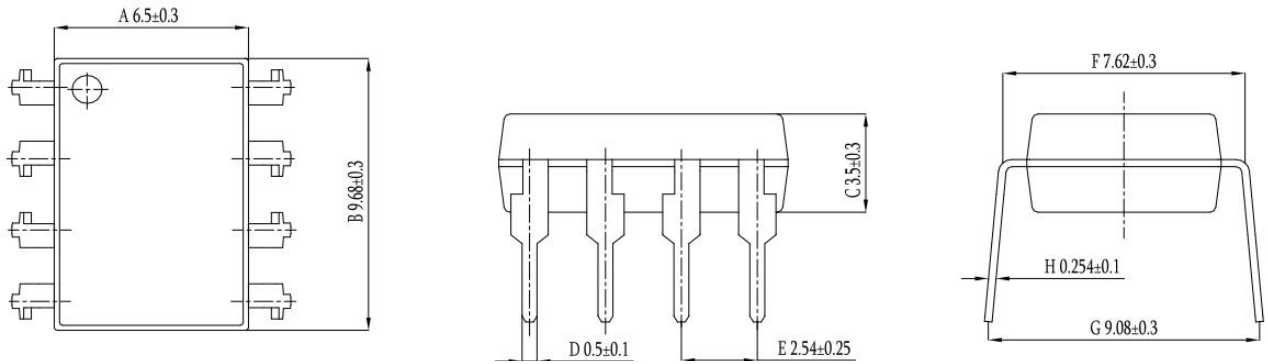

##### DIP8-M

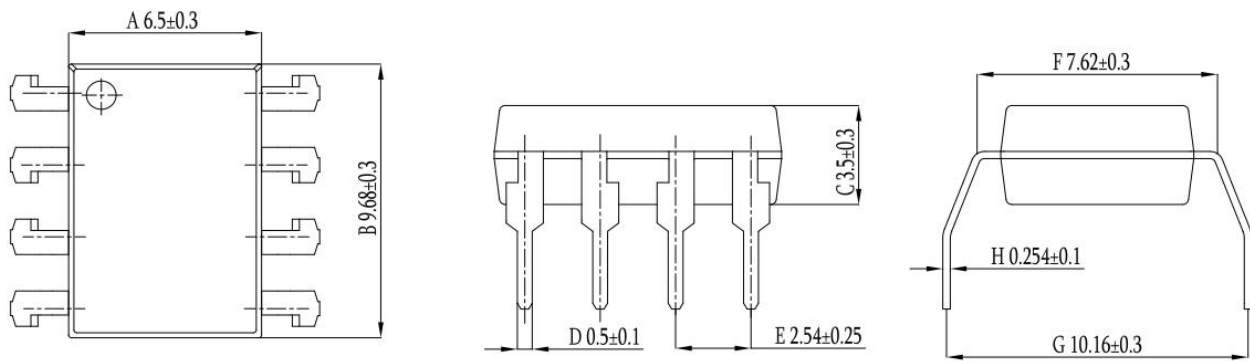

##### SMD8

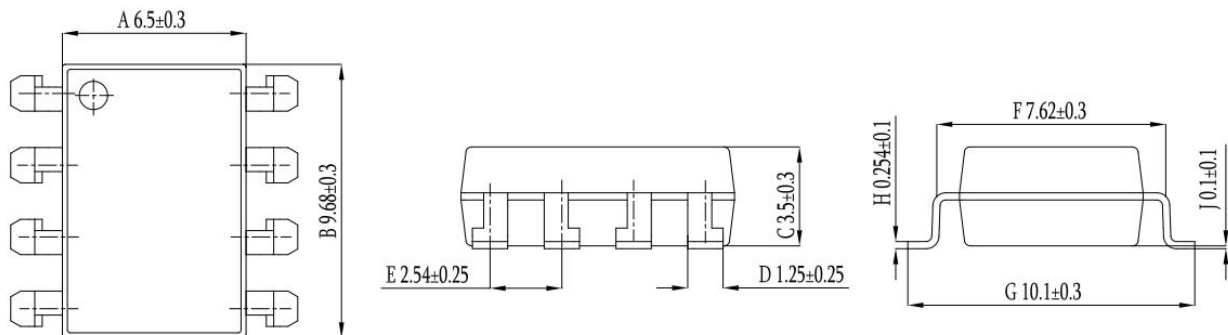

#### SOLDERING FOOTPRINT (unit: mm)

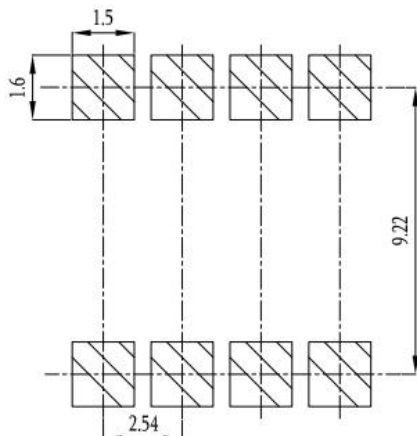

### Reflow soldering

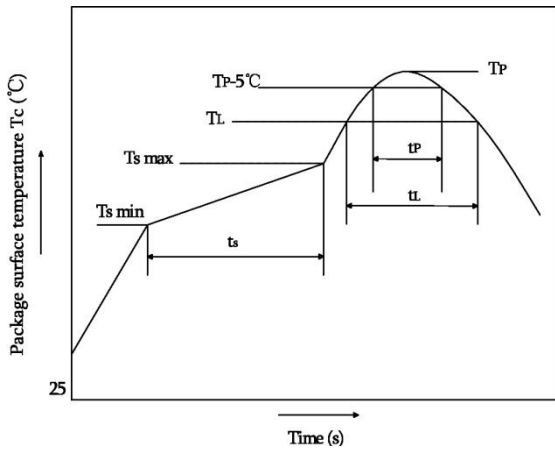

	Symbol	Min	Max	Unit
Preheat temperature	Ts	150	200	°C
Preheat time	ts	60	120	s
Ramp-up rate(Tl to Tp)			3	°C/s
Liquidus temperature	Tl	217		°C
Time above Tl	tL	60	150	s
Peak temperature	Tp		260	°C
Time during which Tc is between (Tp-5) and Tp	tP		30	s
Ramp-down rate(Tp to Tl)			6	°C/s

**Note:**

Reflow soldering is recommended at the temperatures and times shown, no more than three times.

### Wave soldering

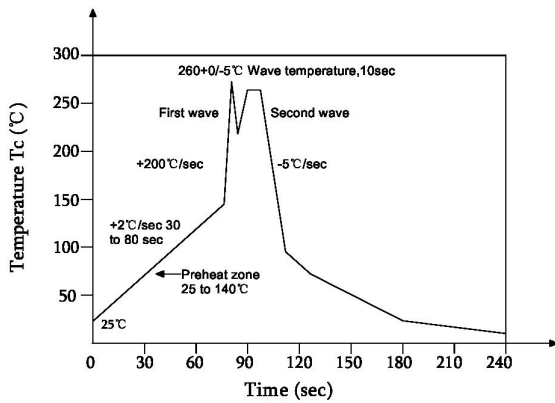

Profile feature	
Average ramp-up rate	~200°C/s
Heating rate during preheat	1°C/s to 2°C/s typical; 4°C/s maximum
Final preheat temperature Ts	~130°C
Preheat time (25°C to Ts)	>60s
Peak temperature Tp	260°C
Time within peak temperature tp	10s
Ramp-down rate	5°C/s maximum

### Soldering with hand soldering iron

- A. Hand soldering iron is only used for product rework or sample testing.
- B. Hand soldering iron requirements: Temperature: 360 °C+5°C within 3s.

### Packing

Package Type	Packing Form	Quantity per Tube & Reel	Quantity per Box	Quantity per Carton	Antistatic Bag Specification	Box Specification	Carton Specification	Note
DIP8	Tube(500mm)	45pcs/tube	50 tubes /box	10 boxes /ctn	190*670mm	520*105*50mm	545*372*235mm	Straight insert type material tube
DIP8-M	Tube(500mm)	45pcs/tube	50 tubes /box	10 boxes /ctn	190*670mm	520*105*50mm	545*372*235mm	Seagull foot (M foot) tube
SMD8	Reel(φ330mm)	1000pcs/reel	2 reels /box	10 boxes /ctn	380*420mm	350*340*60mm	365*330*370mm	Guard band 200mm /min.

#### ■ Summary table

##### ■ DIP8/DIP8-M (Tube)

Qty/tube: 45pcs. Qty/box: 2250pcs.

Qty/ctn: 22500pcs.

Schematic: (unit: mm)

##### ■ SMD8 (Reel)

Qty/reel: 1000pcs. Qty/box: 2000pcs.

Qty/ctn: 20000pcs.

Schematic: (unit: mm)

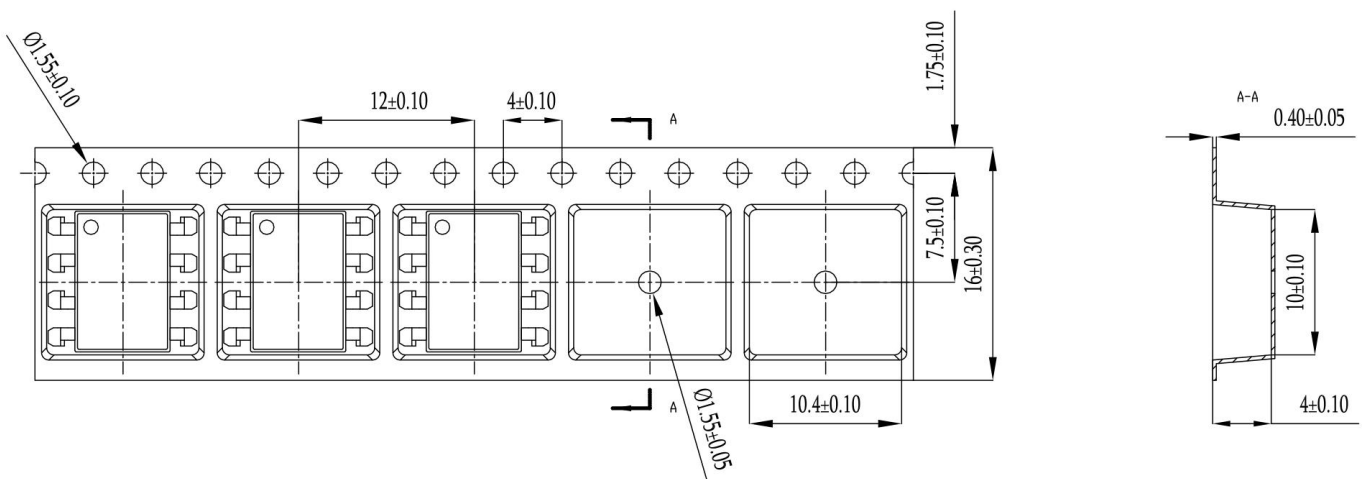

**Attention**

- XINGLIGHT implements dynamic technical updates. Specifications are subject to change. Refer to the official website for the latest version.
- Users must strictly adhere to specified conditions. Failures caused by misuse (overload, high temperature, incompatible circuits) are excluded from warranty.
- Contact technical support for customized validation in critical applications (medical devices, industrial control).
- This document is valid until Dec 31, 2026. Updates will be notified on the official website.
- For further clarification on technical specifications or application solutions, please contact us through official channels.