

Product packaging logic diagram

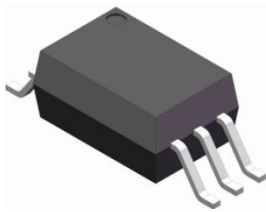

SOP6-W

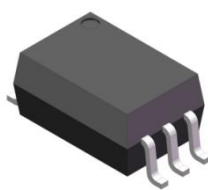

SOP6-P

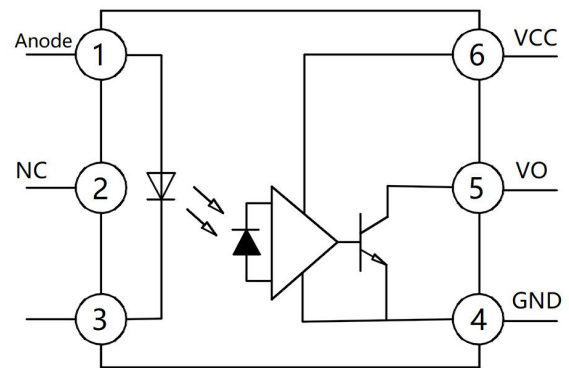

Pin Configuration

Features

- Very high speed: 10MBit/s
- High isolation voltage between input and output ($V_{iso} = 5000V \text{ rms}$)
- Operating Temperature: $-40^{\circ}\text{C} \sim 85^{\circ}\text{C}$
- Environmentally friendly products, compliant with CQC, UL, and VDE requirements

Mechanical Data

- Case: SOP6-W, SOP6-P
- Molding Compound: UL Flammability Classification Rating 94V-0
- Terminals: Matte tin-plated leads; solder ability-per MIL-STD-202, Method 208

Applications

- Widely used in communications and networking, industrial automation and control, motor drive and energy management, medical equipment, and automotive electronics fields.
- Communications and Networking: Fiber optic communication, data center.
- Industrial Automation and Control: PLC and frequency converter, Servo drive system, Industrial robot.
- Motor Drive and Energy Management: Motor control, Motor protection, Power electronics, Consumer Electronics.
- Emerging Technology Fields: Intelligent Transportation System, Medical equipment, Automatic production line.
- Automotive Electronics: In-vehicle Network System, Battery Management System (BMS), EV Charging Station.



Ordering Information

XL 6XX (X) (X) (X) - (U) (N) (Y)
 ① ② ③ ④ ⑤ ⑥ ⑦ ⑧

- ① Brand (XL)
- ② Product series (600, 601, 611)
- ③ Package type(SOP6-P:P; SOP6-W:W)
- ④ Halogen option (None : Halogen free)
- ⑤ CTR Bank(None)
- ⑥ Lead frame (None: Copper)
- ⑦ Customer option 1 (0-9 or A- Z or none)
- ⑧ Customer option 2 (0-9 or A- Z or none)

Part Number	Package	Shipping Quantity	Marking Code
XL601P	SOP6-P	1000pcs / Tape & Reel	XL601

Marking Information

- " XL" denotes brand
- " 6XX" denotes Product series: 00, 01, 11.
- " Y" denotes Year : A(2024), B(2025), C(2026)
- " WW" denotes Week' s number
- " N" denotes the day of Week.



Maximum Ratings (@ T_A = 25°C unless otherwise specified)

Parameter		Symbol	Value	Unit
Input	Forward Current	I _F	50	mA
	Reverse Voltage	V _R	5	V
	Power Dissipation	P _D	100	mW
Output	Collector Output	P _O	85	mW
	Output Current	I _O	50	mA
	Supply Voltage	V _{CC}	7	V
	Output Voltage	V _O	7	V

Thermal Characteristics

Parameter	Symbol	Value	Unit
Isolation Voltage *2	V _{ISO}	5000	Vrms
Operating Temperature	T _{OPR}	-40 ~ +85	°C
Storage Temperature Range	T _{STG}	-55 ~ +125	°C
Soldering Temperature *3	T _{SOL}	260	°C

Notes:

1. 40 to 60% RH, AC for 1 minute
2. For 10 seconds

Electrical Characteristics (@ T_A = 25°C unless otherwise specified)

Parameter		Symbol	Test Condition	Min.	Typ.	Max.	Unit
Input	Forward Voltage	V _F	I _F = 10mA	-	1.33	1.8	V
	Reverse Breakdown Voltage	B _{VR}	I _R =10μA	5	20	45	V
	Capacitance	C _{in}	V _R = 0V, f = 1kHz	-	70	-	pF
	Diode Temperature Coefficient	ΔV _F /ΔT _A	I _F =10mA	-	-1.9	-	mV/°C
Output	High Level Supply Current	I _{CCH}	V _{CC} =5.5V, I _F =0mA	-	6.0	9	mA
	Low Level Supply Current	I _{CCL}	V _{CC} =5.5V, I _F =10mA	-	7.5	10	mA
Transfer Characteristics	High Level Output Current	I _{OH}	V _{CC} =5.5V V _O =5.5V I _F = 250μA	-	2.1	30	μA
	Low Level Output Voltage	V _{OL}	V _{CC} =5.5V I _F =5mA I _{CL} =13mA	-	0.4	0.6	V
	Input Threshold Current	I _{FT}	V _{CC} =5.5V V _O =0.6V I _{OL} =13mA	-	2.4	5	mA
	Isolation Resistance	R _{IO}	V _{IO} = 500Vdc 40~60% R.H.	-	1×10 ¹²	-	Ω
	Floating Capacitance	C _{IO}	f = 1MHz	-	0.6	-	pF

XL600, XL601, XL611

Switching Characteristics (@ $T_A = -40^{\circ}\text{C} \sim 85^{\circ}\text{C}$, $V_{CC} = 5\text{V}$, $I_F = 7.5\text{mA}$, unless otherwise specified)

Parameter		Symbol	Test Condition	Min.	Typ.	Max.	Unit
Propagation Delay Time to Output HIGH Level		T_{PLH}	$C_L = 15\text{pF}$ $R_L = 350\Omega$ $T_A = 25^{\circ}\text{C}$	-	41	100	ns
Propagation Delay Time to Output Low Level		T_{PHL}		-	50	100	ns
Pulse Width Distortion		$ T_{PHL} - T_{PLH} $		-	9	35	ns
Output Rise Time (10–90%)		t_r		-	40	-	ns
Output Rise Time (90–10%)		t_f		-	10	-	ns
Propagation Delay Skew		t_{psk}		-	-	40	ns
Common Mode Transient Immunity(at Logic High)	600	$ CM_H $	$T_A = 25^{\circ}\text{C}, I_F = 0\text{mA}$ $ V_{CM} = 10\text{V(Peak)}$ $V_{OH} = 2.0\text{V}, R_L = 350\Omega$	-	-	-	V/ μs
	601		$T_A = 25^{\circ}\text{C}, I_F = 0\text{mA}$ $ V_{CM} = 50\text{V(Peak)}$ $V_{OH} = 2.0\text{V}, R_L = 350\Omega$	5000	-	-	
	611		$T_A = 25^{\circ}\text{C}, I_F = 0\text{mA}$ $ V_{CM} = 1000\text{V(Peak)}$ $V_{OH} = 2.0\text{V}, R_L = 350\Omega$	20000	-	-	
Common Mode Transient Immunity (at Logic Low)	600	$ CM_L $	$I_F = 7.5\text{mA}, V_{OL} = 0.8\text{V}$ $R_L = 350\Omega, T_A = 25^{\circ}\text{C}$ $ V_{CM} = 10\text{V(Peak)}$	-	-	-	V/ μs
	601		$I_F = 7.5\text{mA}, V_{OL} = 0.8\text{V}$ $R_L = 350\Omega, T_A = 25^{\circ}\text{C}$ $ V_{CM} = 50\text{V(Peak)}$	5000	-	-	
	611		$I_F = 7.5\text{mA}, V_{OL} = 0.8\text{V}$ $R_L = 350\Omega, T_A = 25^{\circ}\text{C}$ $ V_{CM} = 1000\text{V(Peak)}$	20000	-	-	

XL600, XL601, XL611

Ratings and Characteristics Curves (@ $T_A = 25^\circ\text{C}$ unless otherwise specified)

Fig.1 Forward Current vs. Forward Voltage

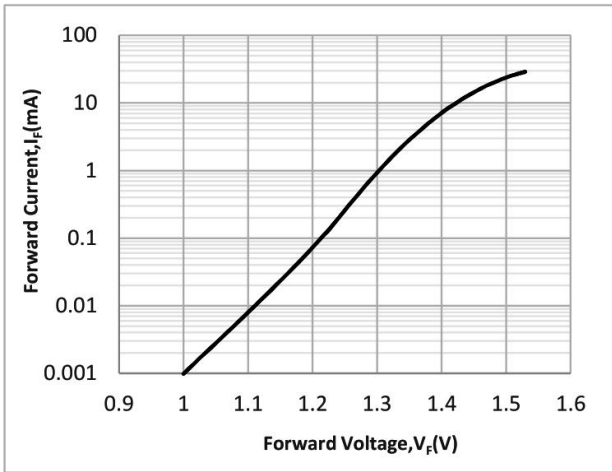

Fig.2 Low Level Output Voltage vs. Ambient Temperature

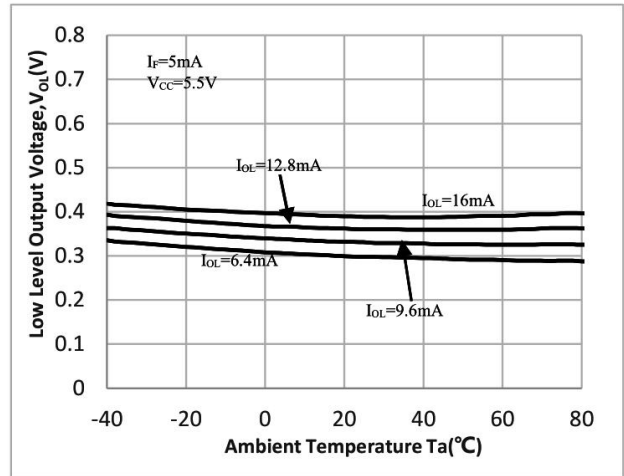

Fig.3 Switching time vs. Forward Current

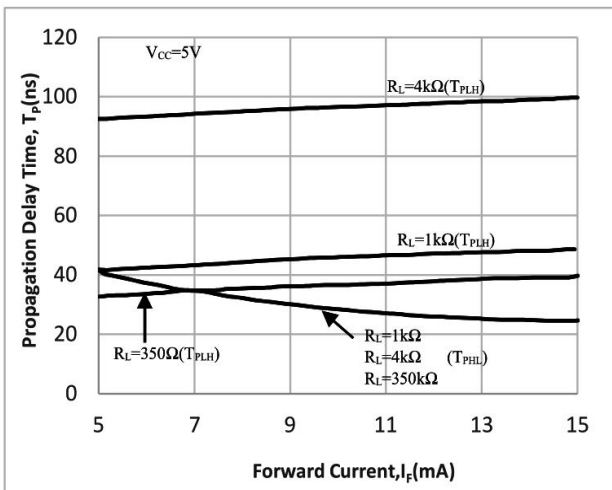

Fig.4 Low Level Output Current vs. Ambient Temperature

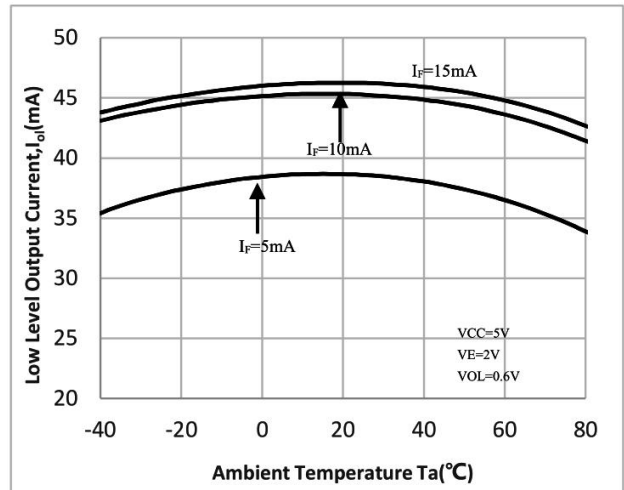

Fig.5 Start Current vs. Ambient Temperature

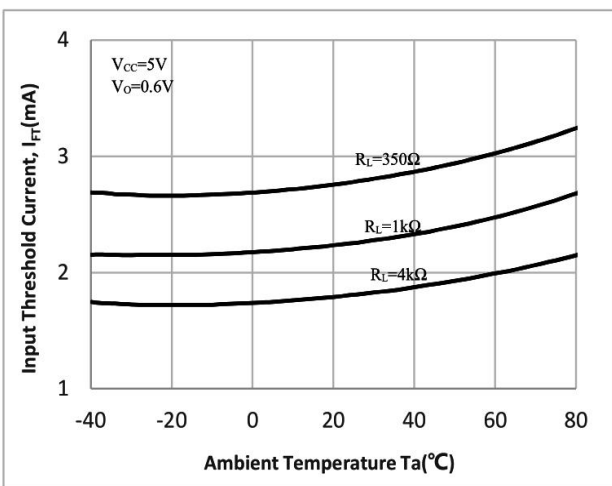
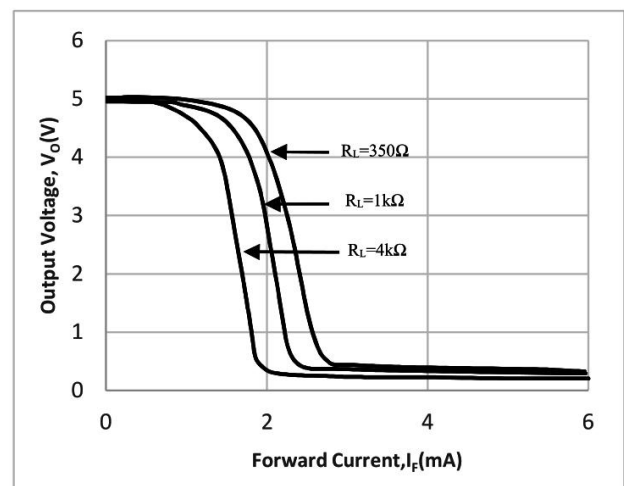

Fig.6 Output Voltage vs. Input Forward Current



XL600, XL601, XL611

Ratings and Characteristics Curves (@ $T_A = 25^\circ\text{C}$ unless otherwise specified)

Fig.7 Pulse Width Distortion vs. Ambient Temperature

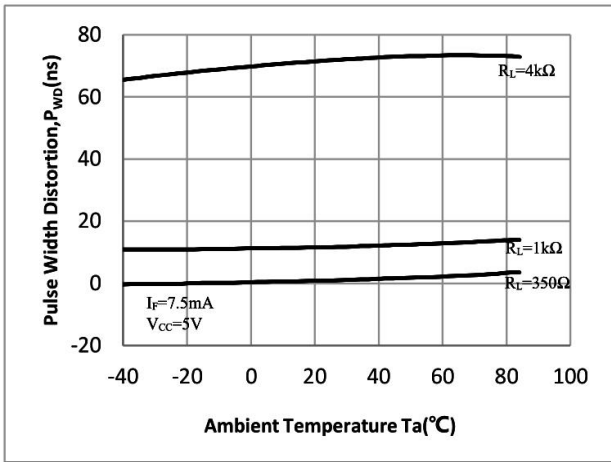

Fig.8 Rise and Fall Time vs. Ambient Temperature

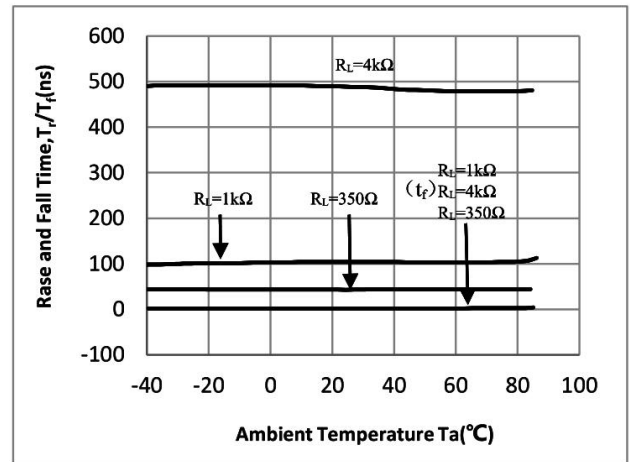

Fig.9 Test Circuit and Waveforms for t_{PLH} , t_{PHL} , t_r and t_f

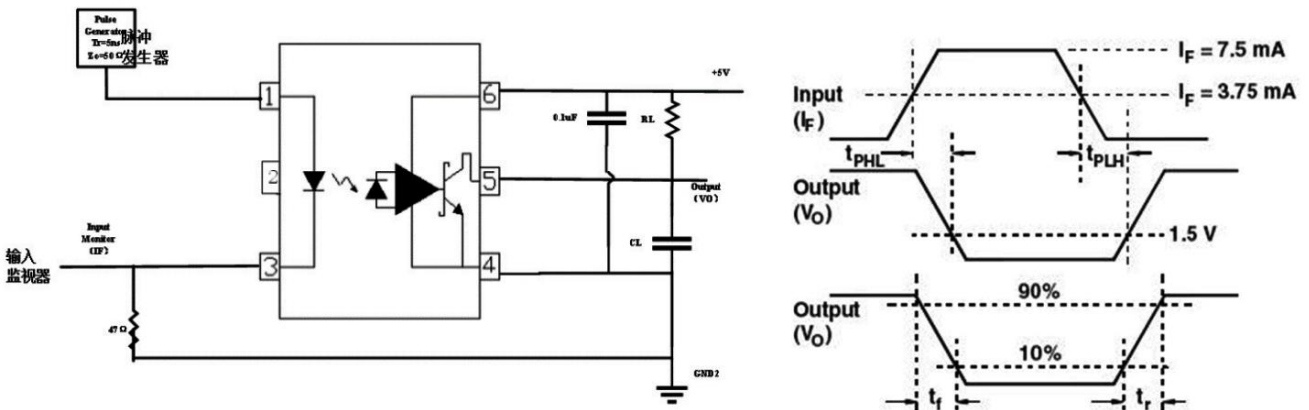
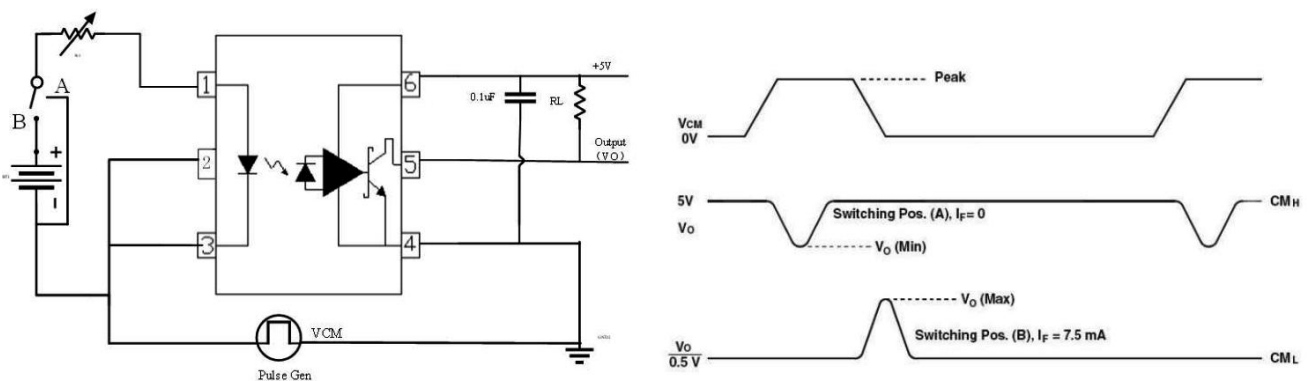

Fig.10 Test Circuit Common Mode Transient Immunity



XL600, XL601, XL611

Package Outline Dimensions (unit: mm)

SOP6-W

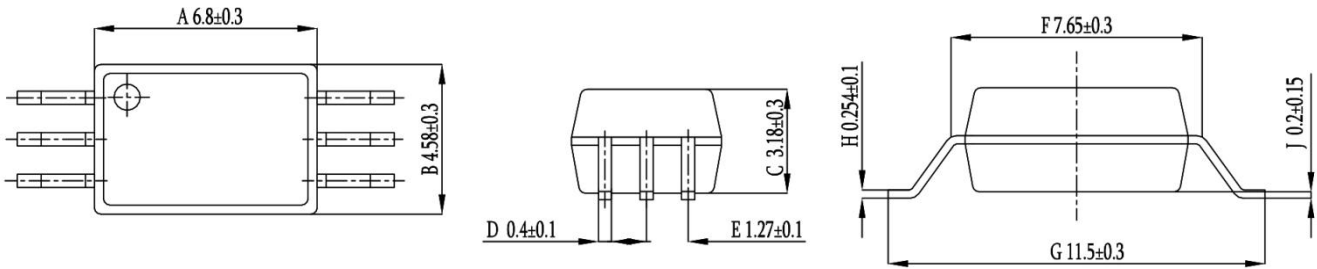

SOP6-P

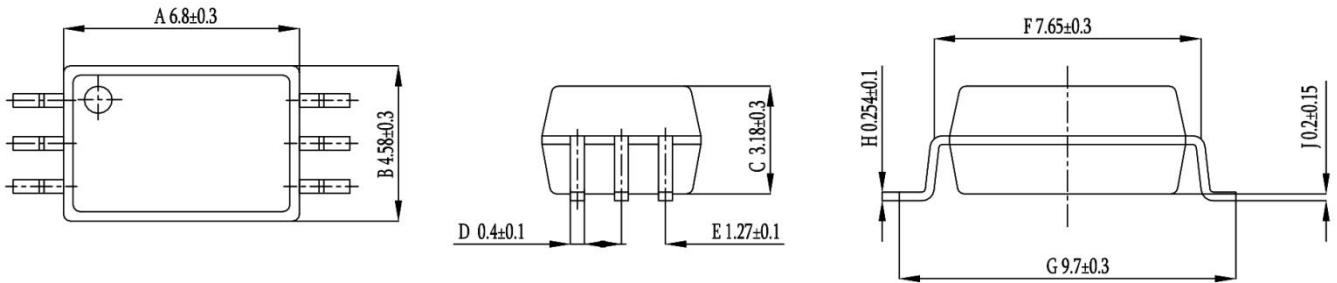

SOLDERING FOOTPRINT (unit: mm)

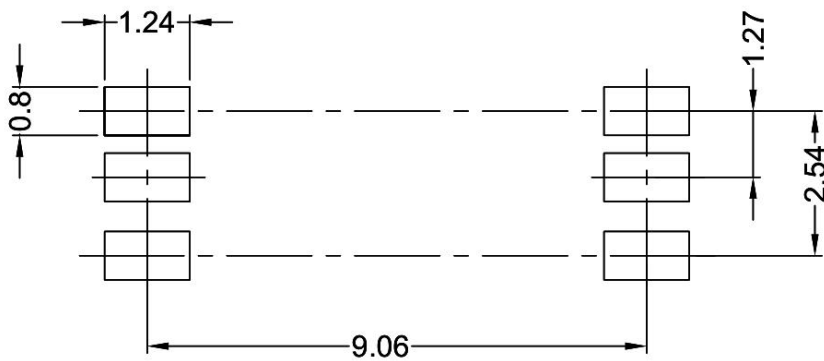

XL600, XL601, XL611

Reflow soldering

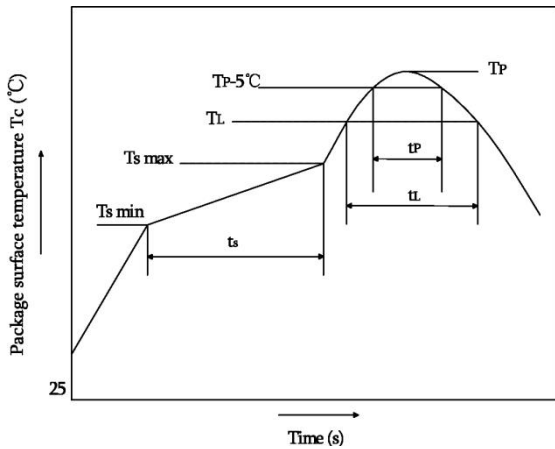

	Symbol	Min	Max	Unit
Preheat temperature	Ts	150	200	°C
Preheat time	ts	60	120	s
Ramp-up rate(TL to TP)			3	°C/s
Liquidus temperature	T _L	217		°C
Time above T _L	t _L	60	150	s
Peak temperature	T _P		260	°C
Time during which T _c is between (T _P -5) and T _P	t _p		30	s
Ramp-down rate(T _P to T _L)			6	°C/s

Note:

Reflow soldering is recommended at the temperatures and times shown, no more than three times.

Wave soldering

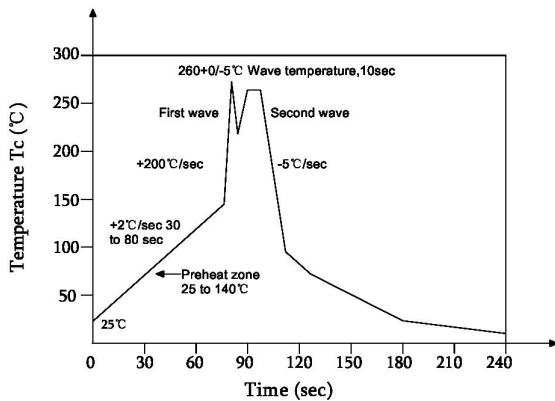

Profile feature	
Average ramp-up rate	~200°C/s
Heating rate during preheat	1°C/s to 2°C/s typical; 4°C/s maximum
Final preheat temperature Ts	~130°C
Preheat time (25°C to Ts)	>60s
Peak temperature Tp	260°C
Time within peak temperature tp	10s
Ramp-down rate	5°C/s maximum

Soldering with hand soldering iron

- Hand soldering iron is only used for product rework or sample testing.
- Hand soldering iron requirements: Temperature: 360 °C+5°C within 3s.

XL600, XL601, XL611

Packing

Package Type	Packing Form	Quantity per Tube & Reel	Quantity per Box	Quantity per Carton	Antistatic Bag Specification	Box Specification	Carton Specification	Note
SOP6	Reel(φ330mm)	1000 pcs/reel	2 reels /box	5 boxes /ctn	380*420mm	350*340*60mm	365*330*370mm	Guard band 200mm/min.

- Summary table

- SOP6 (Reel)

Qty/reel: 1000pcs. Qty/box: 2000pcs.

Qty/ctn: 10000pcs.

Schematic: (unit: mm)

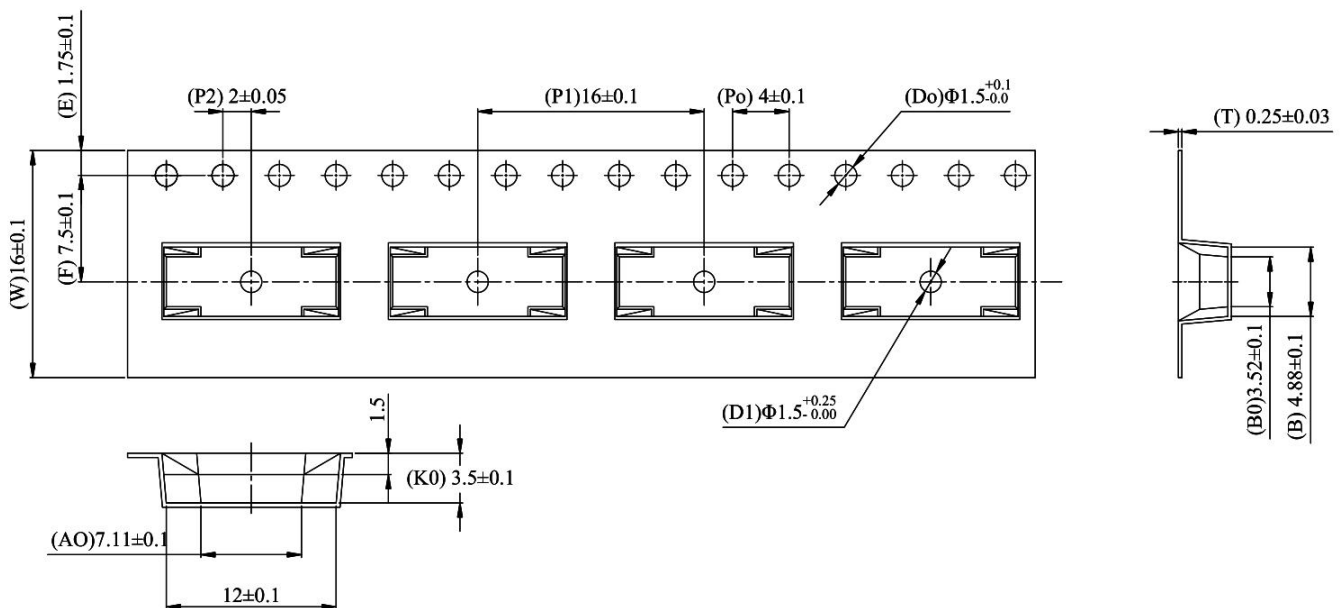

Attention

- XINGLIGHT implements dynamic technical updates. Specifications are subject to change. Refer to the official website for the latest version.
- Users must strictly adhere to specified conditions. Failures caused by misuse (overload, high temperature, incompatible circuits) are excluded from warranty.
- Contact technical support for customized validation in critical applications (medical devices, industrial control).
- This document is valid until Dec 31, 2026. Updates will be notified on the official website.
- For further clarification on technical specifications or application solutions, please contact us through official channels.