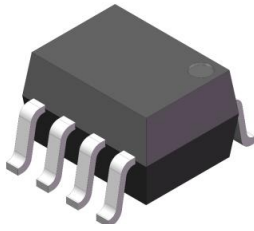
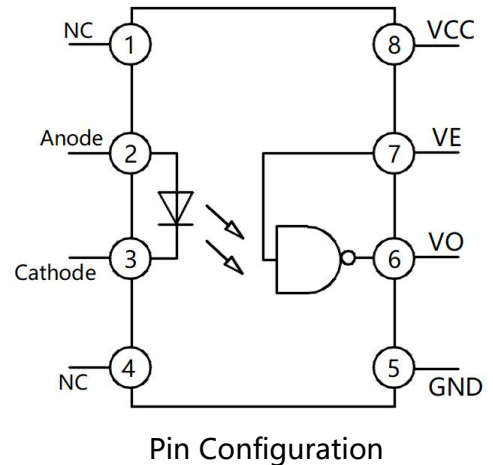


### Product packaging logic diagram



SOP8



### Features

- Very high speed: 10MBit/s
- High isolation voltage between input and output ( $V_{iso} = 3750V$  rms )
- Operating Temperature:  $-40^{\circ}C \sim 100^{\circ}C$
- Environmentally friendly products, compliant with CQC, UL, and VDE requirements

### Mechanical Data

- Case: SOP8
- Molding Compound: UL Flammability Classification Rating 94V-0
- Terminals: Matte tin-plated leads; solder ability-per MIL-STD-202, Method 208

### Applications

- Widely used in communications and networking, industrial automation and control, motor drive and energy management, medical equipment, and automotive electronics fields.
- Communications and Networking: Fiber optic communication, data center.
- Industrial Automation and Control: PLC and frequency converter, Servo drive system, Industrial robot.
- Motor Drive and Energy Management: Motor control, Motor protection, Power electronics, Consumer Electronics.
- Emerging Technology Fields: Intelligent Transportation System, Medical equipment, Automatic production line.
- Automotive Electronics: In-vehicle Network System, Battery Management System (BMS), EV Charging Station.



### Ordering Information

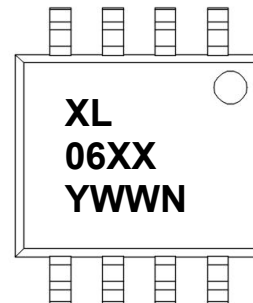


- ① Brand (XL)
- ② Product series (06XX)
- ③ Package type( None: SOP8 )
- ④ Halogen option (None : Halogen free)
- ⑤ CTR Bank(None)
- ⑥ Lead frame (None: Copper)
- ⑦ Customer option 1 (0-9 or A- Z or none)
- ⑧ Customer option 2 (0-9 or A- Z or none)

Part Number	Package	Shipping Quantity	Marking Code
XL06XXP	SOP8	1000pcs / Tape & Reel	XL06XX

### Marking Information

- " XL" denotes brand
- " 06XX" denotes Product series: 00, 01, 11
- " Y" denotes Year : A(2024), B(2025), C(2026)
- " WW" denotes Week' s number
- " N" denotes the day of Week.



### Maximum Ratings (@ T<sub>A</sub> = 25°C unless otherwise specified)

Parameter		Symbol	Value	Unit
Input	Forward Current	IF	50	mA
	Enable input voltage Not exceed VCC by more than 500mV	VE	5.5	V
	Reverse Voltage	VR	5	V
	Power Dissipation	PD	45	mW
Output	Collector Output	PO	100	mW
	Enable input current	IE	5	Ma
	Output Current	IO	50	mA
	Output Voltage	VO	7.0	V

### Thermal Characteristics

Parameter	Symbol	Value	Unit
Isolation Voltage *2	V <sub>ISO</sub>	3750	V <sub>rms</sub>
Operating Temperature	T <sub>OPR</sub>	-40 ~ +100	°C
Storage Temperature Range	T <sub>STG</sub>	-55 ~ +125	°C
Soldering Temperature *3	T <sub>SOL</sub>	260	°C

#### Notes:

1. Pulse width ≤ 1μs, Duty ratio: 0.001
2. 40 to 60% RH, AC for 1 minute
3. For 10 seconds

### Electrical Characteristics (@ T<sub>A</sub> = 25°C unless otherwise specified)

Parameter		Symbol	Condition	Min	Typ	Max	Unit
Input	Forward Voltage	V <sub>F</sub>	I <sub>F</sub> = 10mA	-	1.4	1.8	V
	Reverse Breakdown Voltage	V <sub>R</sub>	I <sub>R</sub> = 10μA	5	-	-	V
	Temperature coefficient of forward voltage	ΔV <sub>F</sub> /ΔT <sub>A</sub>	I <sub>F</sub> = 10mA	-	1.8	-	mV/°C
	Input capacitance	C <sub>IN</sub>	V <sub>F</sub> = 0, f = 1MHz	-	60	-	PF
Output	High level supply current	I <sub>CCH</sub>	I <sub>F</sub> = 10mA, V <sub>E</sub> = 0.5V, V <sub>CC</sub> = 5.5V	-	-	13	mA
	Low level supply current	I <sub>CCL</sub>	I <sub>F</sub> = 0mA, V <sub>E</sub> = 0.5V, V <sub>CC</sub> = 5.5V	-	-	10	mA
	High level enable current	I <sub>EH</sub>	V <sub>E</sub> = 2.0V, V <sub>CC</sub> = 5.5V	-	-	50	mA
	Low level enable current	I <sub>EL</sub>	V <sub>E</sub> = 0.5V, V <sub>CC</sub> = 5.5V	-	140	200	mA
	High level enable voltage	V <sub>EH</sub>	I <sub>F</sub> = 10mA, V <sub>CC</sub> = 5.5V	-	0.01	1	V
	Low level enable voltage*4	V <sub>EL</sub>	I <sub>F</sub> = 10mA, V <sub>CC</sub> = 5.5V	-	-	2	V
Transfer Characteristics	HIGH Level Output Current	I <sub>OH</sub>	V <sub>CC</sub> = 5.5V, V <sub>O</sub> = 5.5V, I <sub>F</sub> = 250μA, V <sub>E</sub> = 2.0V	-	-	100	μA
	LOW Level Output Current	V <sub>OL</sub>	V <sub>CC</sub> = 5.5V, I <sub>F</sub> = 5mA, V <sub>E</sub> = 2.0V, I <sub>CL</sub> = 13mA	-	-	0.6	V
	Input Threshold Current	I <sub>FT</sub>	V <sub>CC</sub> = 5.5V, V <sub>O</sub> = 0.6V, V <sub>E</sub> = 2.0V, I <sub>OL</sub> = 13mA	-	-	5	mA

## XL0600,XL0601,XL0611

**Switching Characteristics** (@  $T_A = -40^{\circ}\text{C} \sim 85^{\circ}\text{C}$ ,  $V_{CC} = 5\text{V}$ ,  $I_F = 7.5\text{mA}$ , unless otherwise specified)

Parameter	Symbol	Condition	Min.	Typ.	Max.	Unit	
Propagation delay time to output High level*5 (Fig.12)	TPHL	CL = 15pF, RL=350Ω, TA=25°C	-	35	75	ns	
Propagation delay time to output High level*5 (Fig.12)	TPLH	CL = 15pF, RL=350Ω, TA=25°C	-	45	75	ns	
Pulse width distortion	Tphl - Tplh	CL = 15pF, RL=350Ω	-	10	35	ns	
Output rise time*7 (Fig.12)	Tr	CL = 15pF, RL=350Ω	-	30	40	ns	
Output fall time*8 (Fig.12)	Tf	CL = 15pF, RL=350Ω	-	10	20	ns	
Enable Propagation Delay Time to Output High Level*9 (Fig.13)	TELH	IF = 7.5mA , VEH=3.5V, CL = 15pF, RL=350Ω	-	30	40	ns	
Enable Propagation Delay Time to Output Low Level*10 (Fig.13)	TEHL	IF = 7.5mA , VEH=3.5V, CL = 15pF, RL=350Ω	-	20	30	ns	
Common Mode Transient Immunity at Logic High (Fig.14)	XL0600	CMH	IF = 7.5mA , VOH=2.0V, RL=350Ω, TA=25°C VCM=10Vp-p	5000	-	-	V/uS
	XL0601		IF = 7.5mA , VOH=2.0V, RL=350Ω, TA=25°C VCM=50Vp-p	5000	-	-	V/uS
	XL0611		IF = 7.5mA , VOH=2.0V, RL=350Ω, TA=25°C VCM=400Vp-p	10000	-	-	V/uS
Common Mode Transient Immunity at Logic High (Fig.15)	XL0611		IF = 7.5mA , VOH=2.0V, RL=350Ω, TA=25°C VCM=400Vp-p	15000	-	-	V/uS
Common Mode Transient Immunity at Logic Low (Fig.14)	XL0600	CML	IF = 0mA , VOL=0.8V, RL=350Ω, TA=25°C VCM=10Vp-p	-	-	-	V/uS
	XL0601		IF = 0mA , VOL=0.8V, RL=350Ω, TA=25°C VCM=50Vp-p	5000	-	-	V/uS
	XL0611		IF = 0mA , VOL=0.8V, RL=350Ω, TA=25°C VCM=400Vp-p	10000	-	-	V/uS
Common Mode Transient Immunity at Logic Low (Fig.15)	XL0611		IF = 7.5mA , VOL=0.8V, RL=350Ω, TA=25°C VCM=400Vp-p	15000	-	-	V/uS

### Ratings and Characteristics Curves (@ $T_A = 25^\circ\text{C}$ unless otherwise specified)

Figure 1. Forward Current vs Forward Voltage

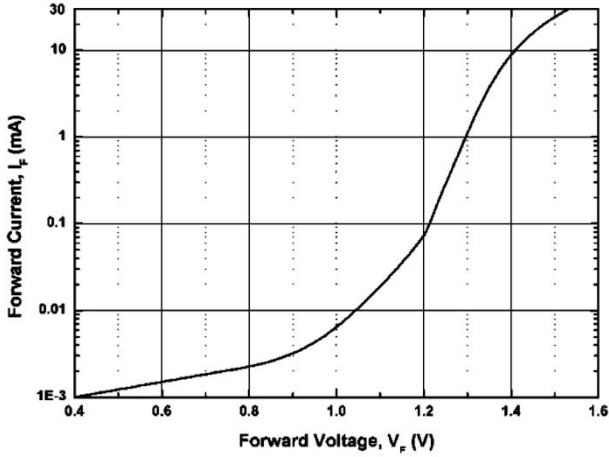


Figure 2. Low Level Output Voltage vs Ambient Temperature

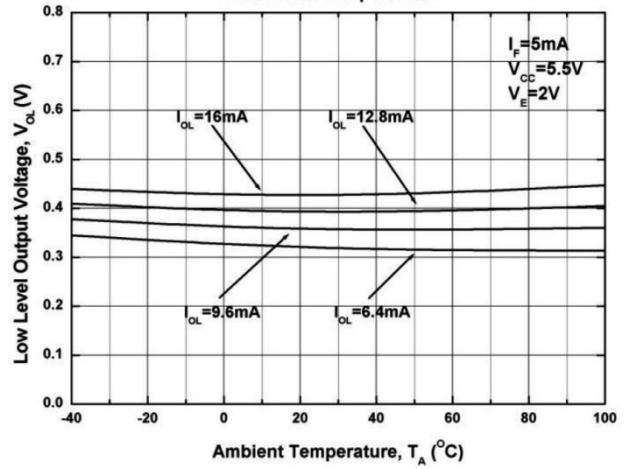


Figure 3. Low Level Output Current vs Ambient Temperature

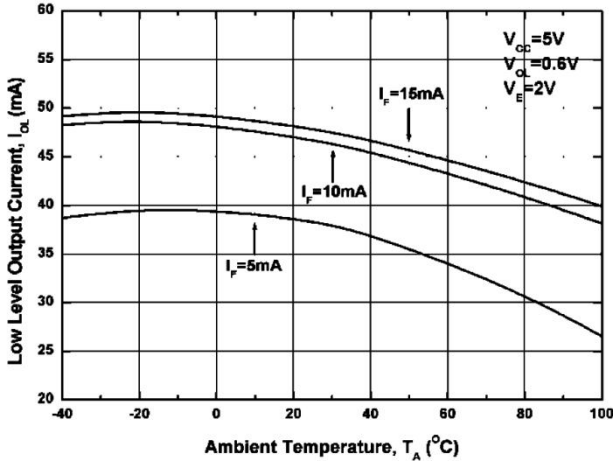


Figure 4. Input Threshold Current vs Ambient Temperature

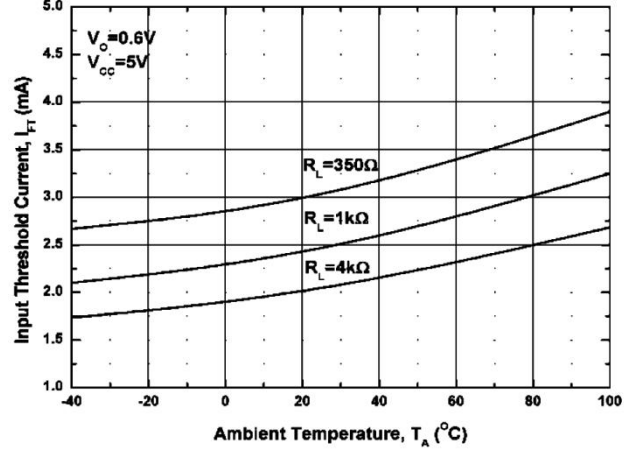


Figure 5. Input Current vs Output Voltage

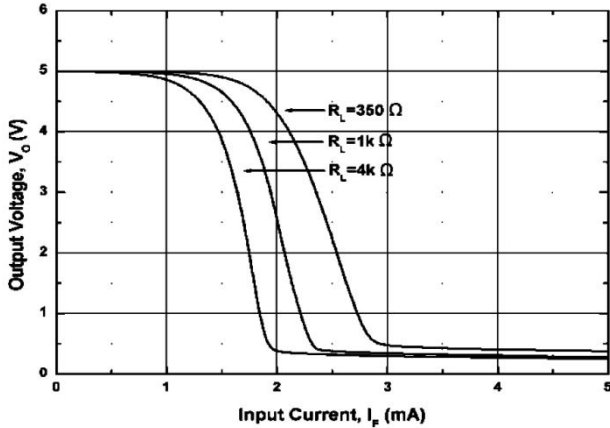
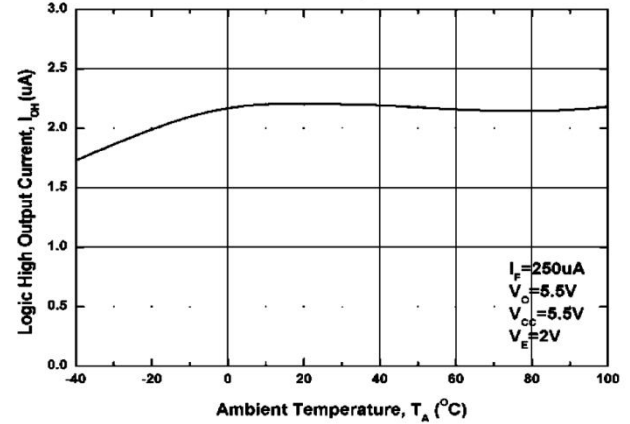


Figure 6. High Level Output Current vs Ambient Temperature



### Ratings and Characteristics Curves (@ $T_A = 25^\circ\text{C}$ unless otherwise specified)

Figure 7. Propagation Delay vs. Forward Current

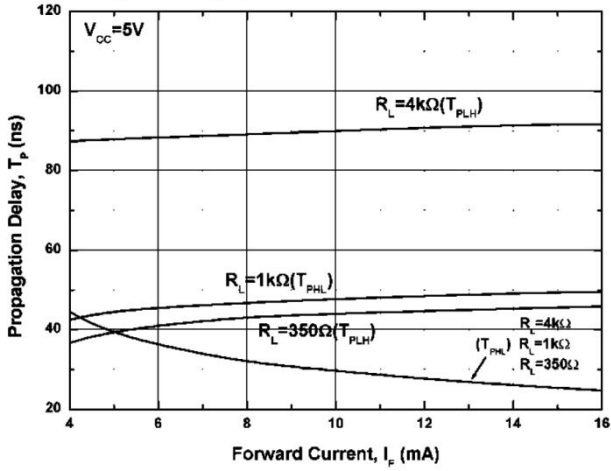


Figure 8. Propagation Delay vs. Temperature

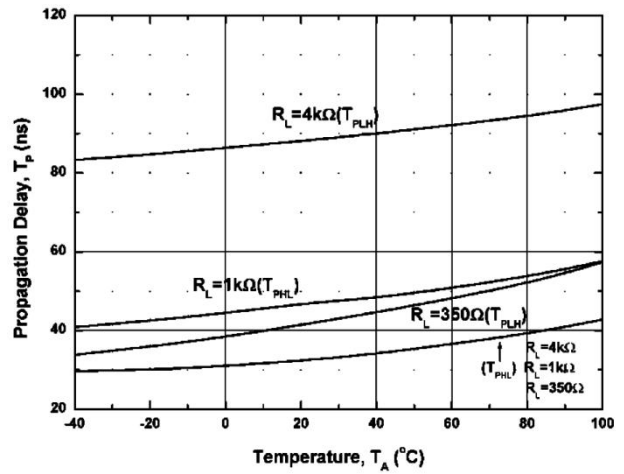


Figure 9. Pulse Width Distortion vs. Temperature

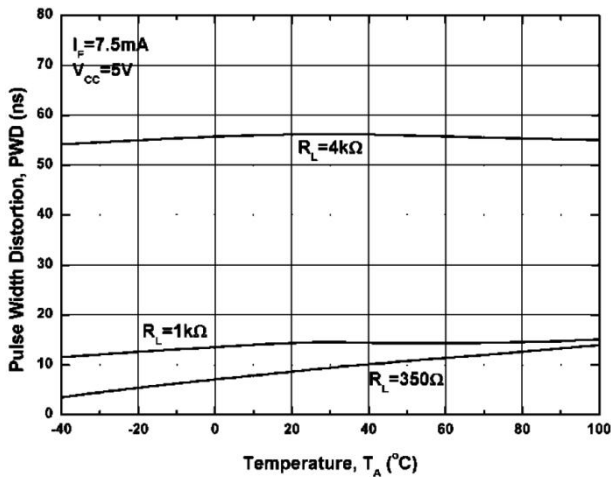


Figure 10. Rise and Fall Time vs. Temperature

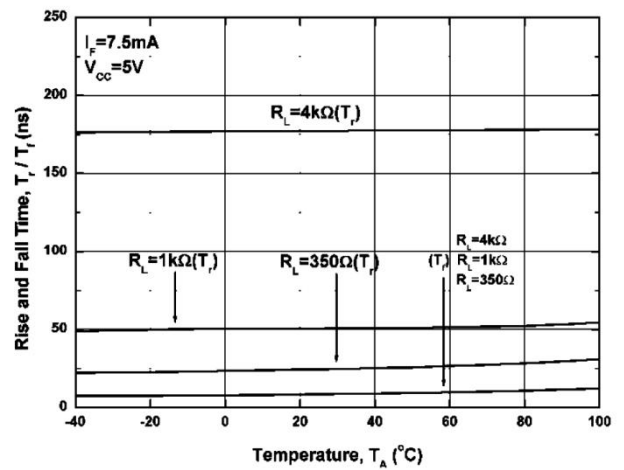
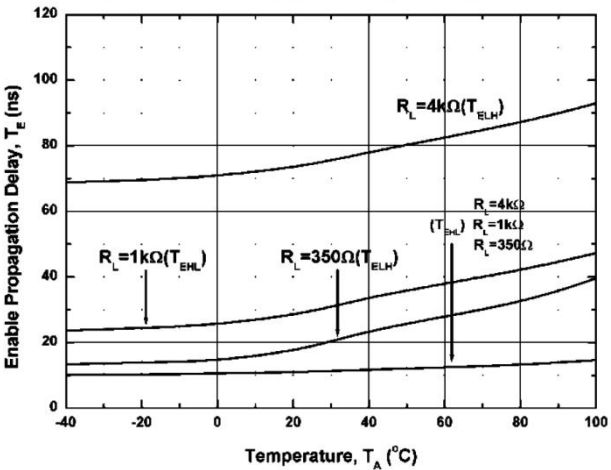


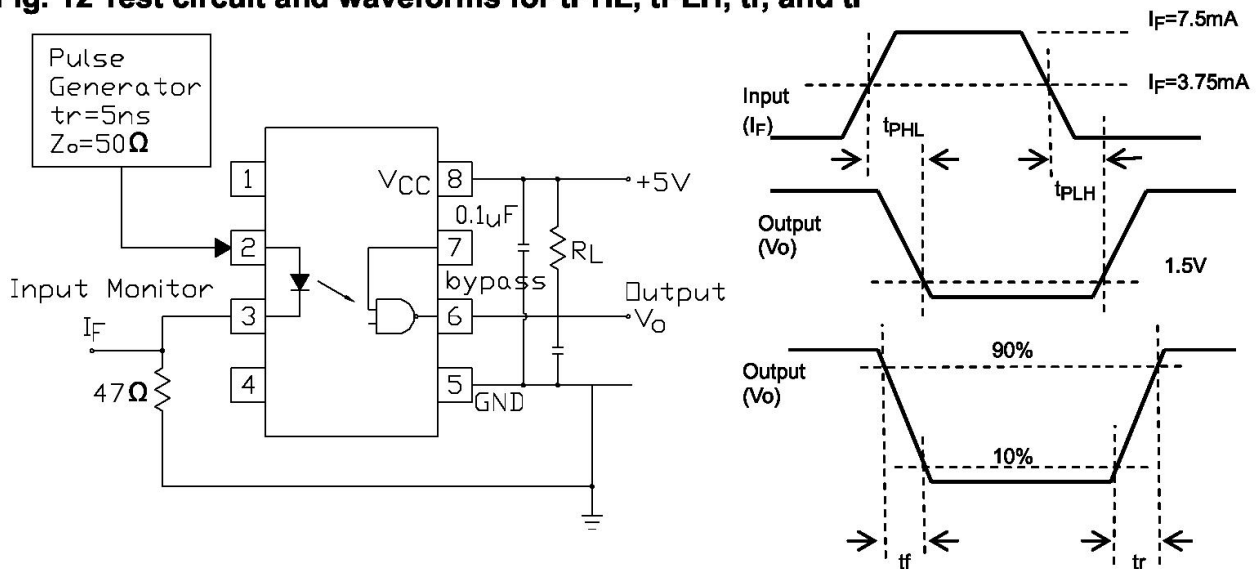
Figure 11. Enable Propagation Delay vs. Temperature



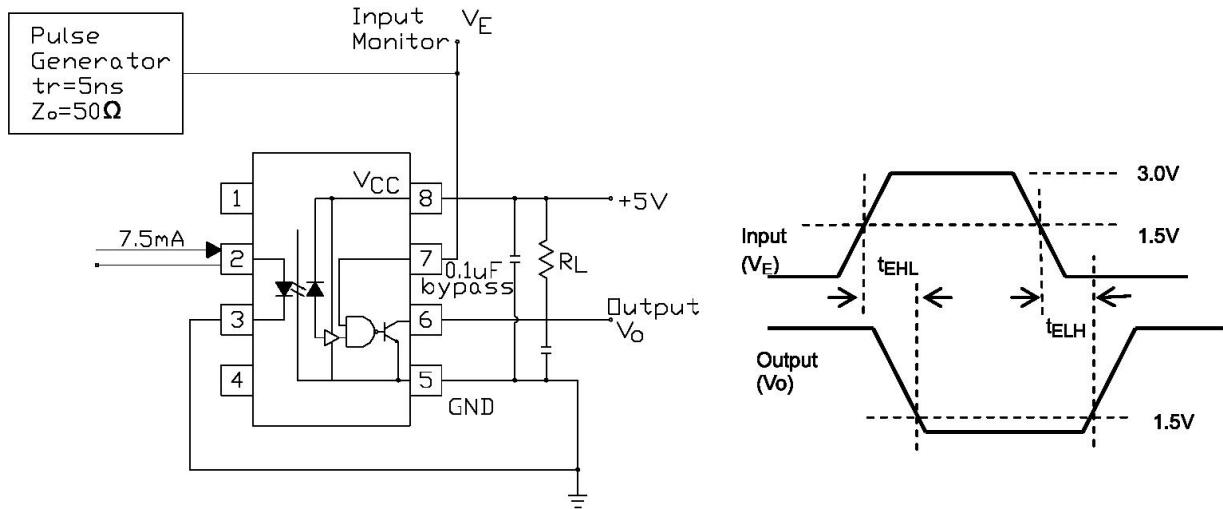
#### Notes

- \*3. The VCC supply must be bypassed by a 0.1μF capacitor or larger. This can be either a ceramic or solid tantalum capacitor with good high frequency characteristic and should be connected as close as possible to the package VCC and GND pins
- \*4. Enable Input – No pull up resistor required as the device has an internal pull up resistor.
- \*5. tPLH – Propagation delay is measured from the 3.75mA level on the HIGH to LOW transition of the input current pulse to the 1.5 V level on the LOW to HIGH transition of the output voltage pulse.
- \*6. tPHL – Propagation delay is measured from the 3.75mA level on the LOW to HIGH transition of the input current pulse to the 1.5 V level on the HIGH to LOW transition of the output voltage pulse.
- \*7. tr – Rise time is measured from the 90% to the 10% levels on the LOW to HIGH transition of the output pulse.
- \*8. tf – Fall time is measured from the 10% to the 90% levels on the HIGH to LOW transition of the output pulse.
- \*9. tELH – Enable input propagation delay is measured from the 1.5V level on the HIGH to LOW transition of the input voltage pulse to the 1.5V level on the LOW to HIGH transition of the output voltage pulse.
- \*10. tEHL – Enable input propagation delay is measured from the 1.5V level on the LOW to HIGH transition of the input voltage pulse to the 1.5V level on the HIGH to LOW transition of the output voltage pulse.
- \*11 CMH– The maximum tolerable rate of rise of the common mode voltage to ensure the output will remain in the HIGH state (i.e., VOUT > 2.0V).
- \*12 CML– The maximum tolerable rate of rise of the common mode voltage to ensure the output will remain in the LOW output state (i.e., VOUT < 0.8V).

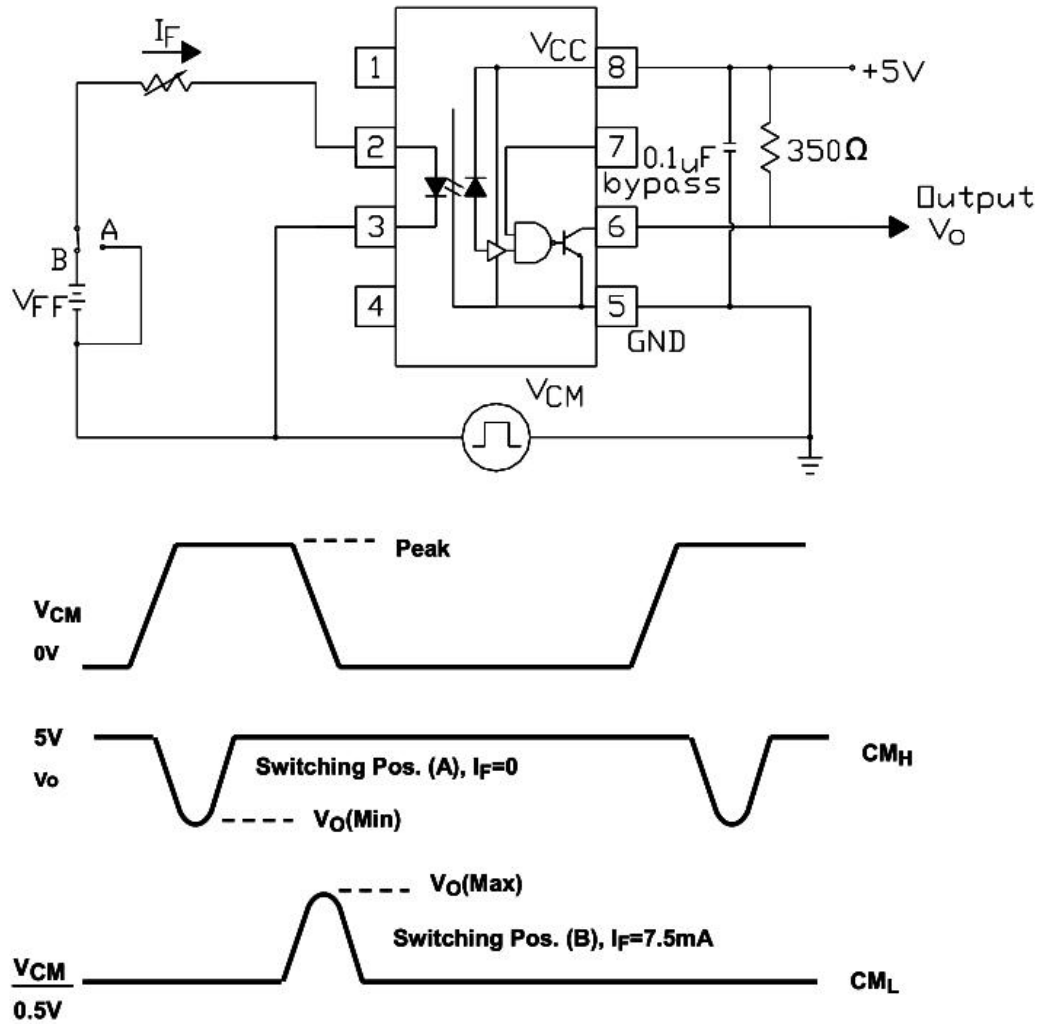
**Fig. 12 Test circuit and waveforms for tPHL, tPLH, tr, and tf**



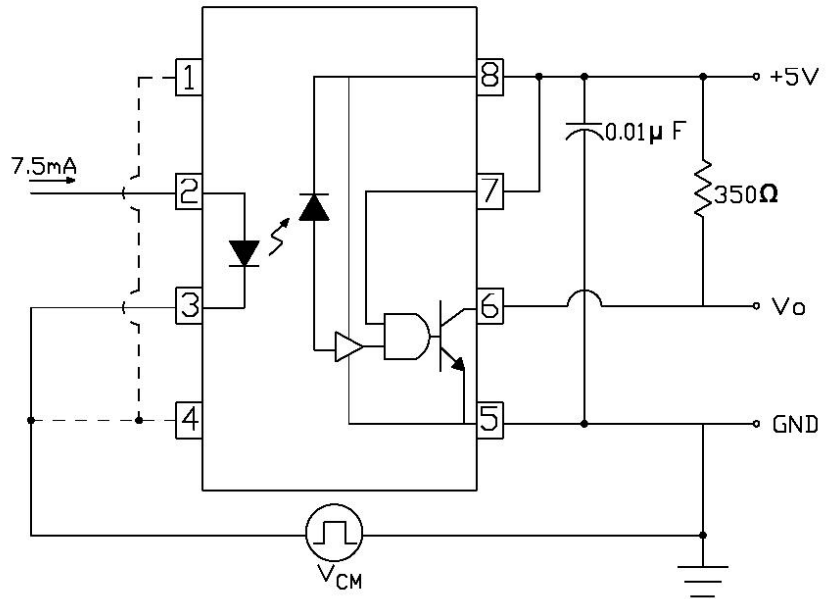
**Fig. 13 Test circuit and waveform for  $t_{EHL}$  and  $t_{ELH}$**



**Fig. 14 Test circuit Common mode Transient Immunity**

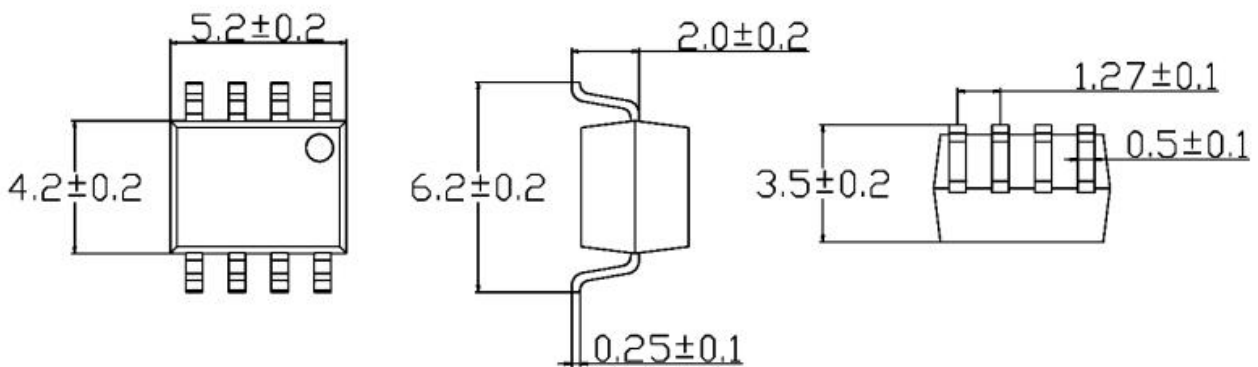


**Fig. 15 Recommended drive circuit for EL0611 families for high-CMR**

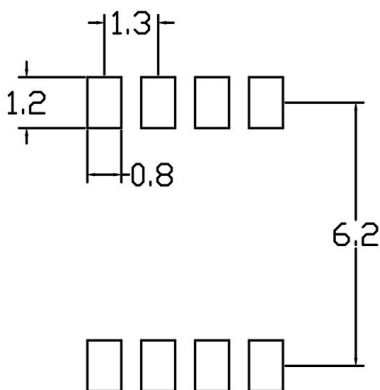


**Package Outline Dimensions (unit: mm)**

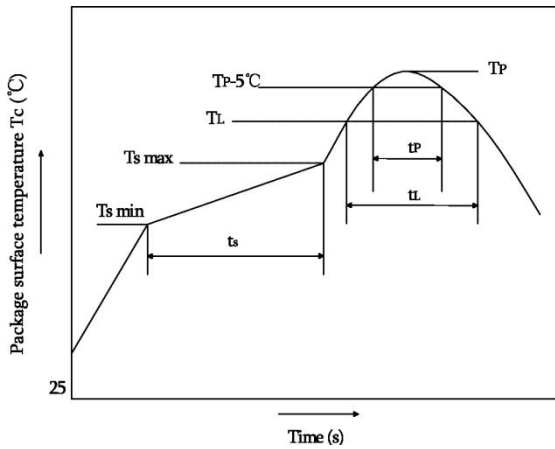
**SOP8**



**SOLDERING FOOTPRINT (unit: mm)**



### Reflow soldering

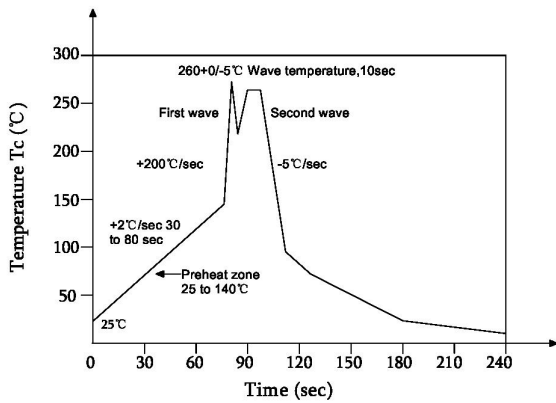


	Symbol	Min	Max	Unit
Preheat temperature	Ts	150	200	°C
Preheat time	ts	60	120	s
Ramp-up rate(TL to TP)			3	°C/s
Liquidus temperature	TL	217		°C
Time above TL	tL	60	150	s
Peak temperature	Tp		260	°C
Time during which Tc is between (Tp-5) and TP	tp		30	s
Ramp-down rate(TP to TL)			6	°C/s

**Note:**

Reflow soldering is recommended at the temperatures and times shown, no more than three times.

### Wave soldering



Profile feature	
Average ramp-up rate	~200°C/s
Heating rate during preheat	1°C/s to 2°C/s typical; 4°C/s maximum
Final preheat temperature Ts	~130°C
Preheat time (25°C to Ts)	>60s
Peak temperature Tp	260°C
Time within peak temperature tp	10s
Ramp-down rate	5°C/s maximum

### Soldering with hand soldering iron

- A. Hand soldering iron is only used for product rework or sample testing.
- B. Hand soldering iron requirements: Temperature: 360 °C±5°C within 3s.

### Packing

Package Type	Packing Form	Quantity per Tube & Reel	Quantity per Box	Quantity per Carton	Antistatic Bag Specification	Box Specification	Carton Specification	Note
SOP8	Reel( $\phi 330$ mm)	1000pcs/reel	2 reels /box	10 boxes /ctn	450*390*0.1mm	340*60*340mm	620*360*365mm	Guard band 200mm min.

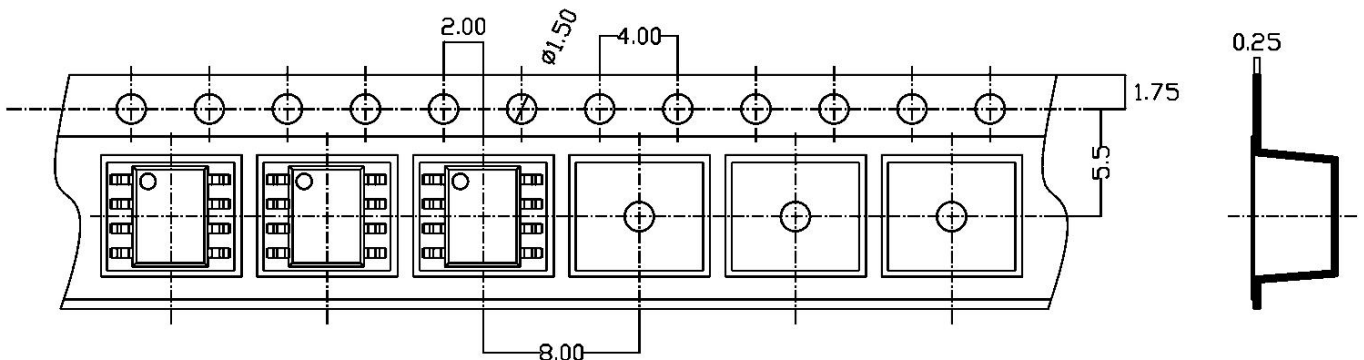
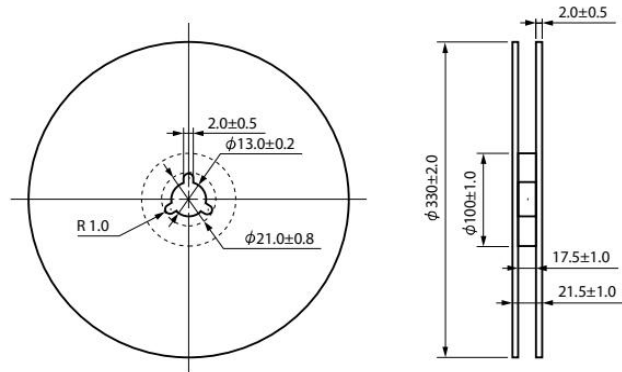
- Summary table

- SOP8 (Reel)

Qty/reel: 1000pcs. Qty/box: 2000pcs.

Qty/ctn: 20000pcs.

Schematic: (unit: mm)



### Attention

- XINGLIGHT implements dynamic technical updates. Specifications are subject to change. Refer to the official website for the latest version.
- Users must strictly adhere to specified conditions. Failures caused by misuse (overload, high temperature, incompatible circuits) are excluded from warranty.
- Contact technical support for customized validation in critical applications (medical devices, industrial control).
- This document is valid until Dec 31, 2026. Updates will be notified on the official website.
- For further clarification on technical specifications or application solutions, please contact us through official channels.