

### Product packaging logic diagram

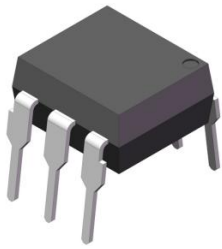

DIP6

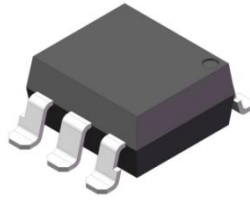

SMD6

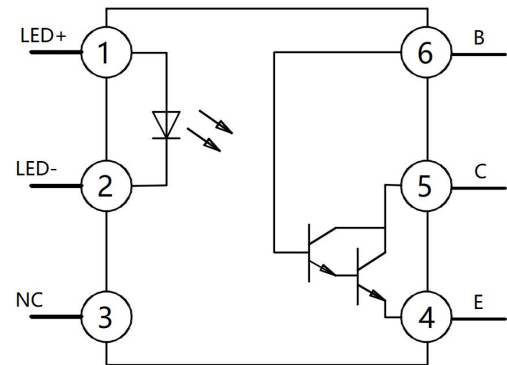

Pin Configuration

### Features

- Current transfer ratio  
(CTR: 50 - 500% at  $I_F = 10\text{mA}$ ,  $V_{CE} = 10\text{V}$ )
- High isolation voltage between input and output ( $V_{iso} = 5000\text{Vrms}$ )
- Operating Temperature:  $-55^\circ\text{C} \sim 100^\circ\text{C}$
- Environmentally friendly products, compliant with CQC, UL, and VDE requirements

### Mechanical Data

- Case: DIP6, SMD6
- Molding Compound: UL Flammability Classification Rating 94V-0
- Terminals: Matte tin-plated leads; solder ability-per MIL-STD-202, Method 208

### Applications

- It is widely used in the feedback control loops of switching power supplies and the isolation between main circuits and control circuits, ensuring stable output voltage and quickly transmitting fault signals to trigger protection mechanisms in the event of overload or short circuit.
- Photovoltaic energy storage system
- Data collection, inverter control, protection circuit
- Industrial automation control
- Relay drive, motor control, PLC interface
- Power management
- Switching power supply feedback isolation, Home appliance power control



### Ordering Information

XL    4NXX    (X)    (X) - (U)    (N)    (Y)  
 ①        ②        ③        ④        ⑤        ⑥        ⑦

- ① Brand(XL)
- ② Product series( 4N29,4N30, 4N31, 4N32, 4N33 )
- ③ Package type( DIP6:None, SMD6:S )
- ④ Halogen option(None :Halogen free)
- ⑤ Lead frame (None: Copper)
- ⑥ Customer option 1 (0-9 or A-Z or none)
- ⑦ Customer option 2 (0-9 or A-Z or none)

Part Number	Package	Shipping Quantity	Marking Code
XL4NXX	DIP6	65pcs / Tube	XL4NXX
XL4NXXS	SMD6	1000pcs / Tape & Reel	XL4NXX

### Marking Information

- " XL" denotes brand.
- " 4NXX" denotes product series: 29, 30, 31, 32, 33
- " Y" denotes Year : A(2024), B(2025), C(2026)
- " WW" denotes Week' s number .
- " N" denotes the day of Week.

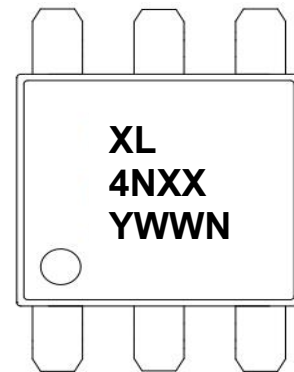

#### Maximum Ratings (@ T<sub>A</sub> = 25°C unless otherwise specified)

Parameter		Symbol	Value	Unit
Input	Forward Current	I <sub>F</sub>	60	mA
	Forward Peak Current* <sup>1</sup>	I <sub>FP</sub>	1	A
	Reverse Voltage	V <sub>R</sub>	6	V
	Power Dissipation	P <sub>D</sub>	70	mW
Output	Collector Power Dissipation	P <sub>C</sub>	150	mW
	Collected Current	I <sub>C</sub>	100	mA
	Collector-Emitter voltage	V <sub>CEO</sub>	50	V
	Emitter-Base voltage	V <sub>EB0</sub>	8	V
	Collector-Base voltage	V <sub>CB0</sub>	30	V
	Emitter-Collector voltage	V <sub>ECO</sub>	5	V

#### Thermal Characteristics

Parameter	Symbol	Value	Unit
Total Power Dissipation	P <sub>TOT</sub>	220	mW
Isolation Voltage * <sup>2</sup>	V <sub>ISO</sub>	5000	V <sub>rms</sub>
Operating Temperature	T <sub>OPR</sub>	-55 ~ +100	°C
Storage Temperature Range	T <sub>STG</sub>	-55 ~ +125	°C
Soldering Temperature * <sup>3</sup>	T <sub>SOL</sub>	260	°C

#### Notes:

1. Pulse width ≤ 1μs, Duty ratio: 0.001
2. 40 to 60% RH, AC for 1 minute. At this time, pins 1, 2 & 3 are shorted, and pins 4, 5 & 6 are shorted together.
3. For 10 seconds

### XL4NXX

#### Electrical Characteristics (@ T<sub>A</sub> = 25°C unless otherwise specified)

Parameter		Symbol	Test Condition	Min.	Typ.	Max.	Unit	
Input	Forward Voltage	V <sub>F</sub>	I <sub>F</sub> = 10mA	-	1.3	1.5	V	
	Reverse Current	I <sub>R</sub>	V <sub>R</sub> = 3V	-	-	10	μA	
	Input Capacitance	C <sub>t</sub>	V = 0V, f = 1kHz	-	50	-	pF	
Output	Collector Dark Current	I <sub>CEO</sub>	V <sub>CE</sub> =10V	-	-	50	nA	
	Collector-Base Breakdown Voltage	BV <sub>CBO</sub>	I <sub>B</sub> =0.1mA, I <sub>F</sub> =0mA	50	-	-	V	
	Collector-Emitter Breakdown Voltage	BV <sub>CEO</sub>	I <sub>C</sub> =0.1mA, I <sub>F</sub> =0mA	40	-	-	V	
	Emitter-Collector Breakdown Voltage	BV <sub>ECO</sub>	I <sub>E</sub> =0.1mA, I <sub>F</sub> =0mA	7	-	-	V	
Transfer Characteristics	Current Transfer Ratio	4N31	CTR	I <sub>F</sub> =10mA, V <sub>CE</sub> =10V	50	-	-	%
		4N29, 4N30			100	-	-	%
		4N32, 4N33			500	-	-	%
	Collector-Emitter Saturation Voltage	V <sub>CE(sat)</sub>	I <sub>F</sub> =8mA, I <sub>C</sub> =2mA	-	-	1	V	
	Isolation Resistance	R <sub>ISO</sub>	DC500V, 40~60%R.H.	-	10 <sup>11</sup>	-	Ω	
	Isolation Capacitance	C <sub>f</sub>	V=0, f=1MHz	-	0.8	-	pF	
	Turn On Time	T <sub>on</sub>	V <sub>CE</sub> =10V	-	-	5	μs	
	Turn Off Time	T <sub>off</sub>	I <sub>C</sub> =50mA, R <sub>L</sub> =100Ω	-	-	100	μs	

## Ratings and Characteristics Curves (@ $T_A = 25^\circ\text{C}$ unless otherwise specified)

Fig.1 Forward Current vs. Forward Voltage

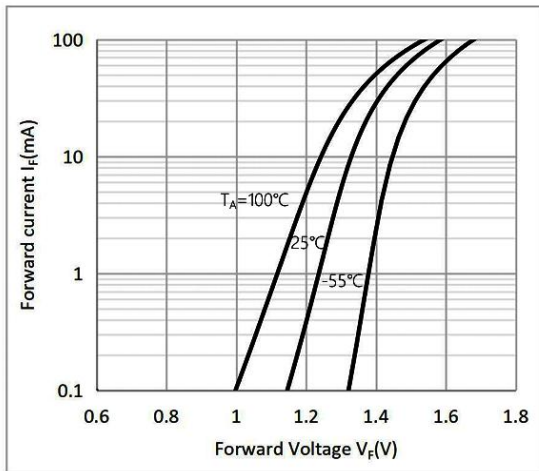

Fig.2 Current Transfer Ratio vs. Ambient Temperature

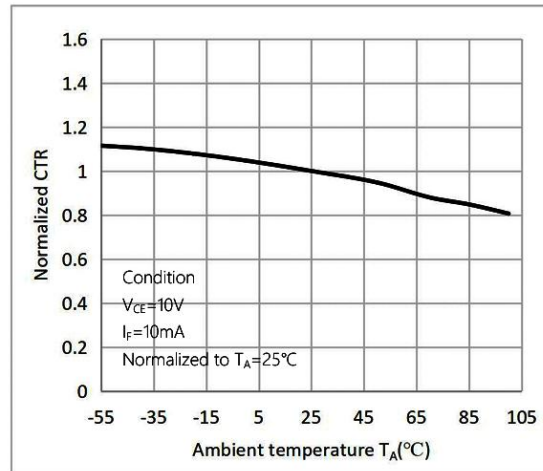

Fig.3 Normalized Current Transfer Ratio vs. Forward Current

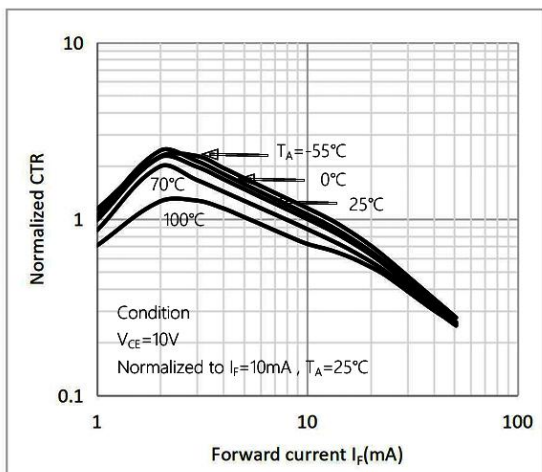

Fig.4 Collector Dark Current vs. Ambient Temperature

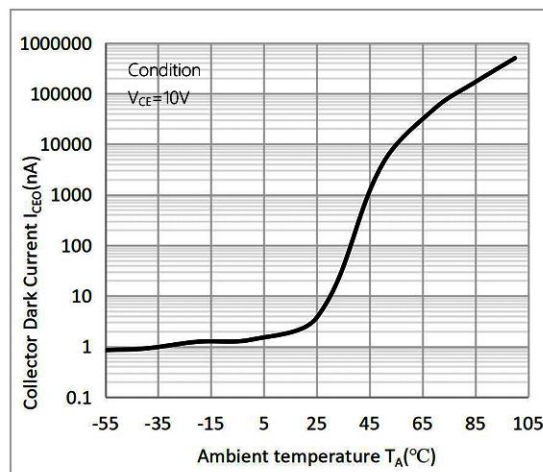

Fig 5. Turn-on Time vs Forward Current

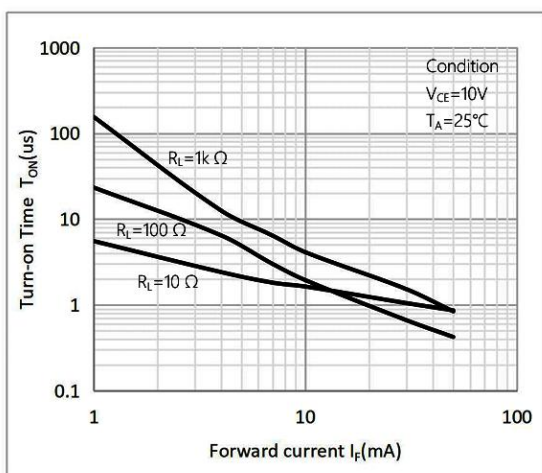
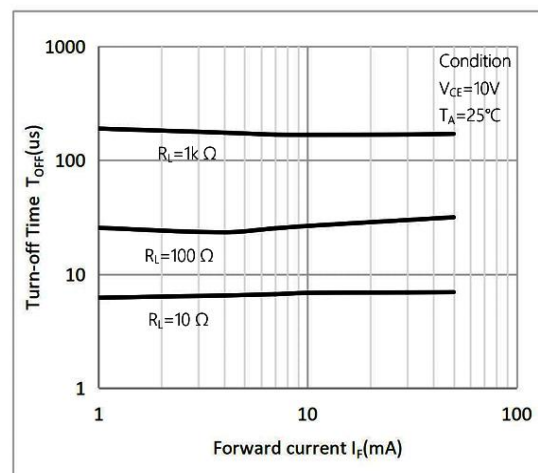
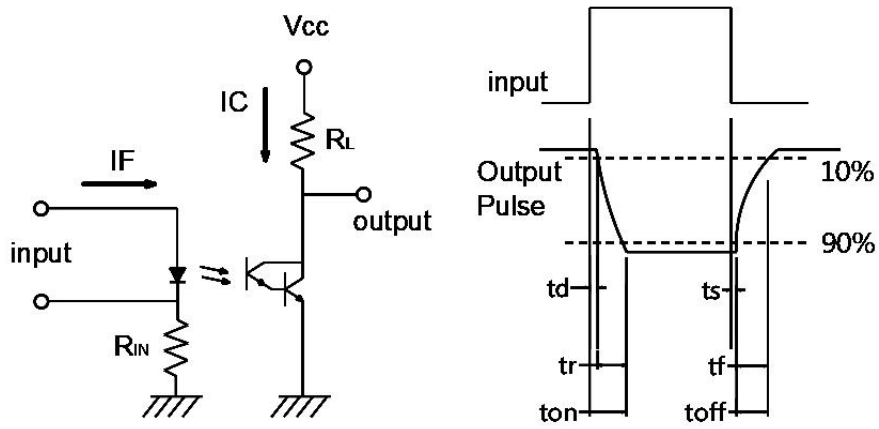

Fig 6. Turn-off Time vs Forward Current



## Switching Time Test Circuit (@ $T_A = 25^\circ\text{C}$ unless otherwise specified)



### Package Outline Dimensions (unit: mm)

#### DIP6

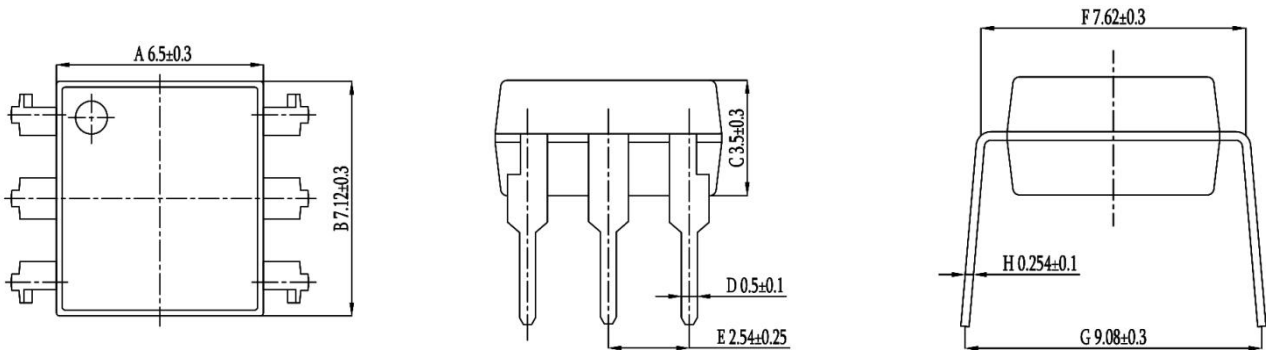

#### SMD6

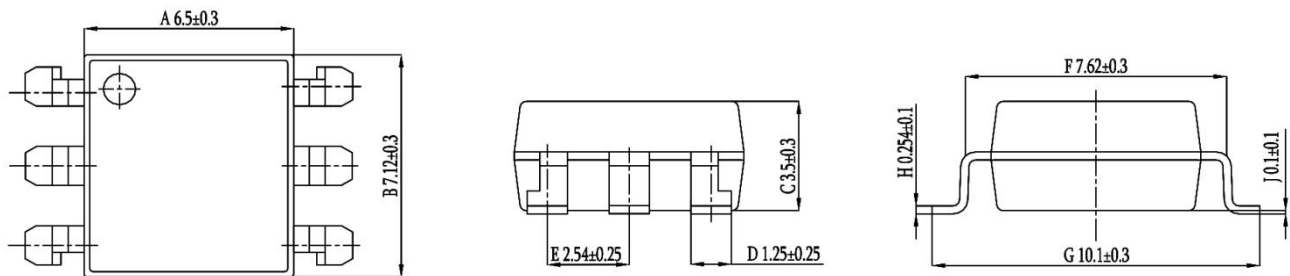

### SOLDERING FOOTPRINT (unit: mm)

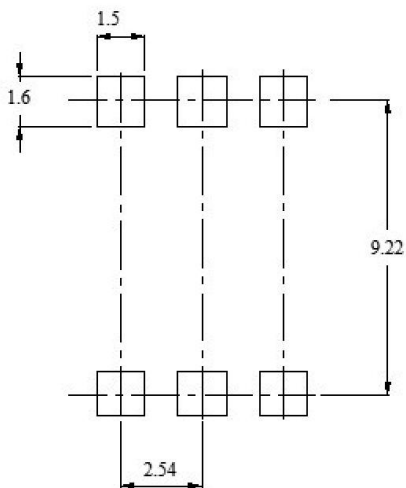

### Reflow soldering

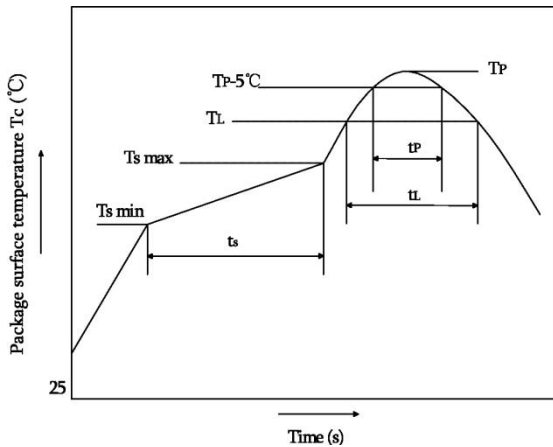

	Symbol	Min	Max	Unit
Preheat temperayure	Ts	150	200	°C
Preheat time	ts	60	120	s
Ramp-up ratea(TL to TP)	-	-	3	°C/s
Liquidus temperature	TL	217		°C
Time above TL	tL	60	150	s
Peak temperature	Tp	-	260	°C
Time during which Tc is between (TP-5) and TP	tp	-	30	s
Ramp-down rate(TP to TL)	-	-	6	°C/s

**Note:**

Reflow soldering is recommended at the temperatures and times shown, no more than three times.

### Wave soldering

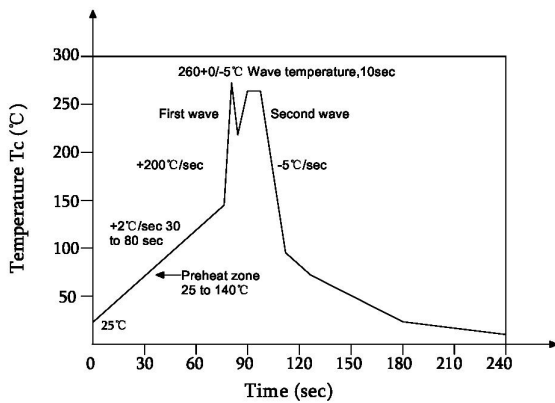

Profile feature	
Average ramp-up rate	~200°C/s
Heating rate during preheat	1°C/s to 2°C/s typical; 4°C/s maximum
Final preheat temperature Ts	~130°C
Preheat time (25°C to Ts)	>60s
Peak temperature Tp	260°C
Time within peak temperature tp	10s
Ramp-down rate	5°C/s maximum

### Soldering with hand soldering iron

- A. Hand soldering iron is only used for product rework or sample testing.
- B. Hand soldering iron requirements: Temperature: 360 °C+5°C within 3s.

### Packing

Package Type	Packing Form	Quantity per Tube & Red	Quantity per box	Quantity per carton	Antistatic Bag Specification	BOX Specification	Carton Specification	Note
DIP6	Tube(500mm)	65pcs/tube	50 tube/box	10 boxes/ctn	190*670mm	520*105*50mm	545*372*235mm	Straight insert type Material tube
SMD6	Reel(Ø330mm)	1000pcs/reel	2 reels/box	10 boxes/ctn	380*420mm	350*340*60mm	365*330*370mm	Guard band 200mm/min

#### ■ Summary table

##### ■ DI6 (Tube)

Qty/ tube: 65pcs. Qty/box: 3250pcs.

Qty/ctn: 32500pcs.

Schematic: (unit:mm)

##### ■ SMD6 (Reel)

Qty/reel: 1000pcs. Qty/box: 2000pcs.

Qty/ctn: 20000pcs.

Schematic: (unit:mm)

#### Tape \$ Reel Packing Option T1

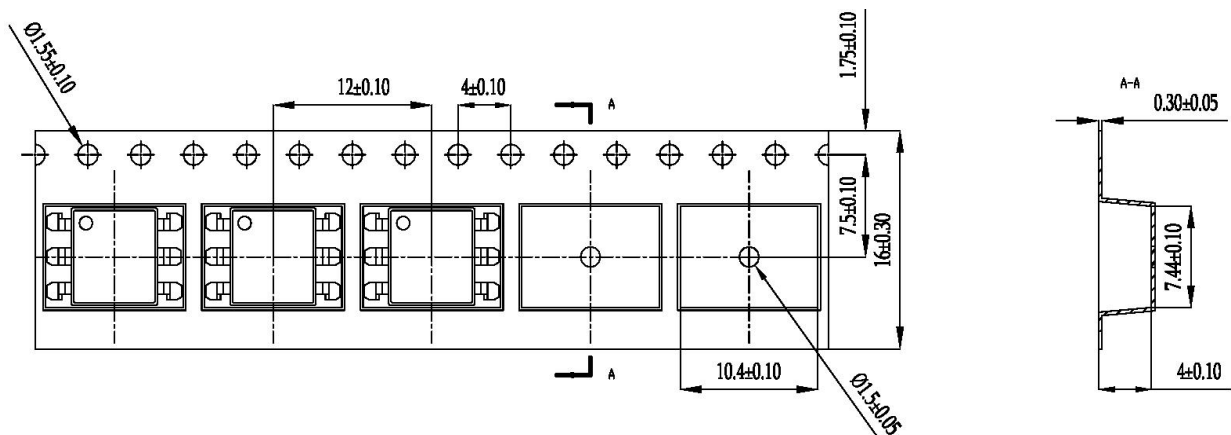

Tape \$ Reel Packing Option T2

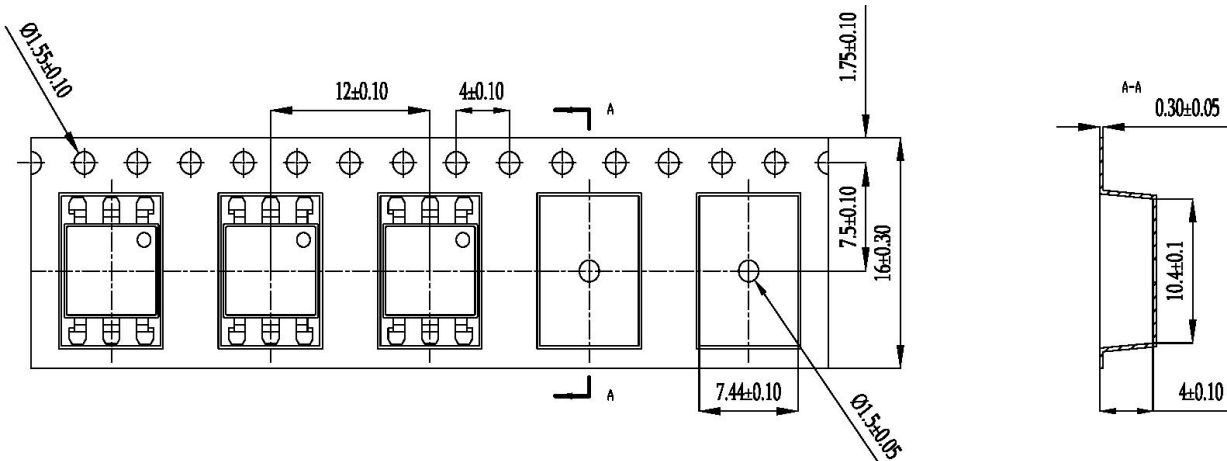

**Attention**

- XINGLIGHT implements dynamic technical updates. Specifications are subject to change. Refer to the official website for the latest version.
- Users must strictly adhere to specified conditions. Failures caused by misuse (overload, high temperature, incompatible circuits) are excluded from warranty.
- Contact technical support for customized validation in critical applications (medical devices, industrial control).
- This document is valid until Dec 31, 2026. Updates will be notified on the official website.
- For further clarification on technical specifications or application solutions, please contact us through official channels.