

Product packaging logic diagram

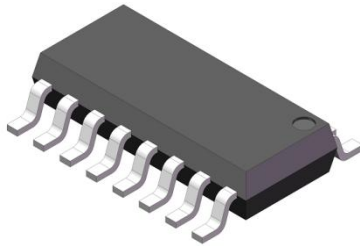

SOP16

Features

- Current transfer ratio (CTR: 50~600% at $I_F = 5\text{mA}$, $V_{CE} = 5\text{V}$)
- High isolation voltage between input and output
($V_{iso} = 3750\text{Vrms}$)
- Collector - emitter breakdown voltage $BV_{CEO} \geq 80\text{V}$
- Operating Temperature: $-55^\circ\text{C} \sim 110^\circ\text{C}$
- Environmentally friendly products, compliant with CQC, UL, and VDE requirements

Mechanical Data

- Case: SOP16
- Molding Compound: UL Flammability Classification Rating 94V-0
- Terminals: Matte tin-plated leads; solder ability-per MIL-STD-202, Method 208

Applications

- It is widely used in the feedback control loop of switching power supply and the isolation between the main circuit and the control circuit, ensuring the stability of the output voltage and quickly transmitting the fault signal to trigger the protection mechanism in the case of overload or short circuit.
- In applications such as PLCs (Programmable Logic Controllers), motor drives, and sensor interfaces, it is used for signal isolation to prevent high-voltage noise from interfering with low-voltage control logic.
- For signal isolation in serial communication interfaces (e.g., RS-232,) to improve anti-interference capability.
- Consumer electronics: household appliances, smart home devices (smart lighting, smart sockets), computers and peripherals (printers, monitors), etc.
- Lighting control: AC transistor optocoupler is suitable for dimming control, smart switching, and wireless control, supporting AC input.

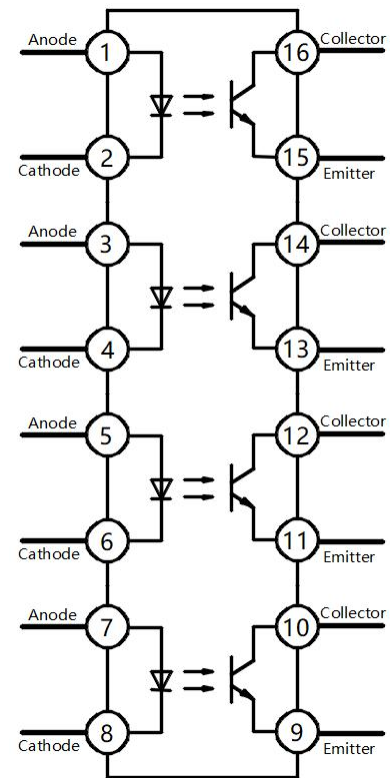

Pin Configuration



Ordering Information

XL Q3H7 (X) (X) - (U) (N) (Y)
 ① ② ③ ④ ⑤ ⑥ ⑦

- ① Brand (XL)
- ② Product series (Q3H7)
- ③ Package type (None: SOP16)
- ④ Halogen option (None :Halogen free)
- ⑤ Lead frame (None: Copper)
- ⑥ Customer option 1 (0-9 or A-Z or none)
- ⑦ Customer option 2 (0-9 or A-Z or none)

Marking Information

- " XL" denotes brand.
- " Q3H7" denotes Product series.
- " Y" denotes Year : A(2024), B(2025), C(2026)
- " WW" denotes Week' s number .
- " N" denotes the day of Week.

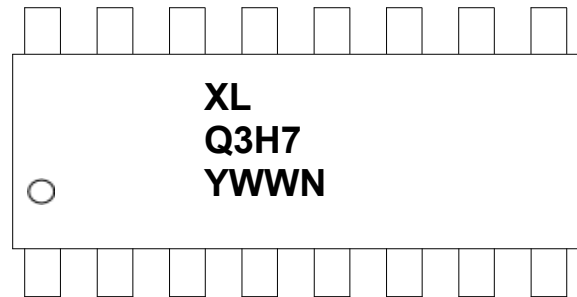

Part Number	Package	Shipping Quantity	Marking Code
XLQ3H7	SOP16	1000pcs / Tape & Reel	XLQ3H7

Maximum Ratings (@ T_A = 25°C unless otherwise specified)

Parameter		Symbol	Value	Unit
Input	Forward Current	I _F	50	mA
	Peak Forward Current *1	I _{FM}	1	A
	Reverse Voltage	V _R	6	V
	Power Dissipation	P _D	70	mW
Output	Collector Power Dissipation	P _C	150	mW
	Collector Current	I _C	50	mA
	Collector-Emitter Voltage	V _{CEO}	80	V
	Emitter-Collector Voltage	V _{ECO}	7	V

Thermal Characteristics

Parameter	Symbol	Value	Unit
Total Power Dissipation	PTOT	200	mW
Isolation Voltage *1	VISO	3750	Vrms
Operating Temperature	TOPR	-55 ~ +110	°C
Storage Temperature Range	TSTG	-55 ~ +125	°C
Soldering Temperature *2	TSOL	260	°C

Notes:

1. Pulse width ≤ 1μs, Duty ratio: 0.001
2. 40 to 60% RH, AC for 1 minute
3. For 10 seconds

Electrical Characteristics (@ TA = 25°C unless otherwise specified)

Parameter		Symbol	Test Condition	Min.	Typ.	Max.	Unit
Input	Forward Voltage	VF	IF = 20mA	-	1.2	1.4	V
	Reverse Current	IR	VR = 4V	-	-	10	μA
	Input Capacitance	Cin	VR = 0V, f = 1kHz	-	30	250	pF
Output	Collector-Emitter Dark Current	ICEO	VCE = 20V, IF = 0	-	-	100	nA
	Collector-Emitter Breakdown Voltage	BVCEO	IC = 0.1mA, IF = 0	80	-	-	V
	Emitter-Collector Breakdown Voltage	BVECO	IE = 10μA, IF = 0	7	-	-	V
Transfer Characteristics	Current Transfer Ratio	CTR	IF = 5 mA, VCE = 5V	50	-	600	%
	Collector-Emitter Saturation Voltage	VCE(sat)	IF = 20mA, IC = 1mA	-	0.1	0.2	V
	Isolation Resistance	RISO	DC500V, 40~60%R.H	5x10 ¹⁰	1x10 ¹¹	-	Ω
	Isolation current	Risc	DC6000V, 40~60%R.H	-	---	2	μA
	Floating Capacitance	CIO	VIO = 0, f = 1MHz	-	0.3	1.0	pF
	Turn On Time	Ton	VCE=2V, RL= 100	-	4	18	μs
Turn Off Time	Toff	Ω IC=2mA	-	3	18		

Ratings and Characteristics Curves (@ $T_A = 25^\circ\text{C}$ unless otherwise specified)

Fig.1 Relative Current Transfer Ratio vs. Forward Current

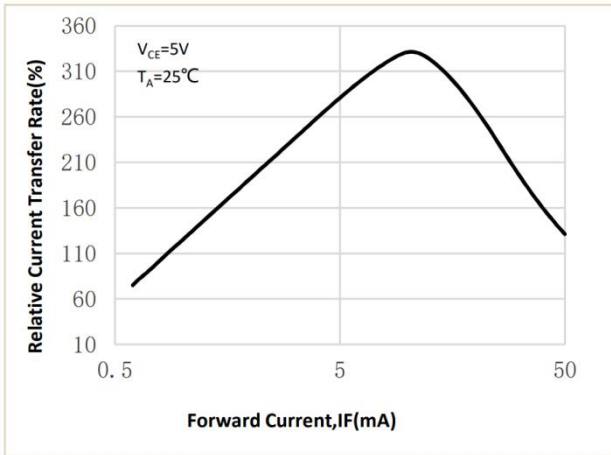

Fig.2 Forward Current vs. Forward Voltage

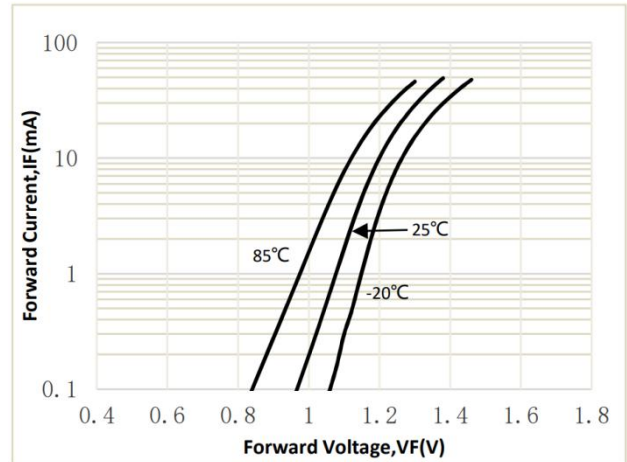

Fig.3 Collector Current vs. Collector-emitter Voltage

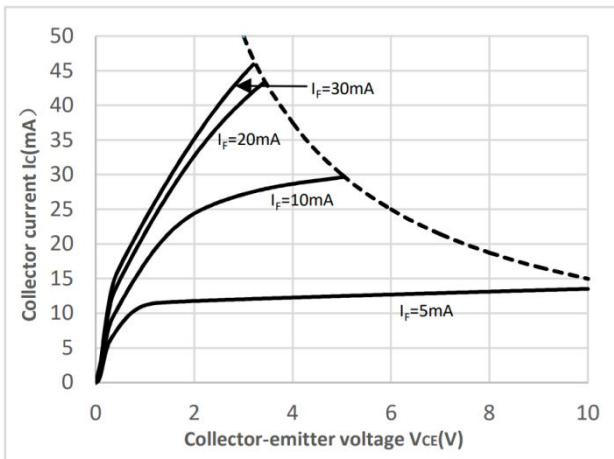

Fig.4 Relative Current Transfer Ratio vs. Ambient Temperature

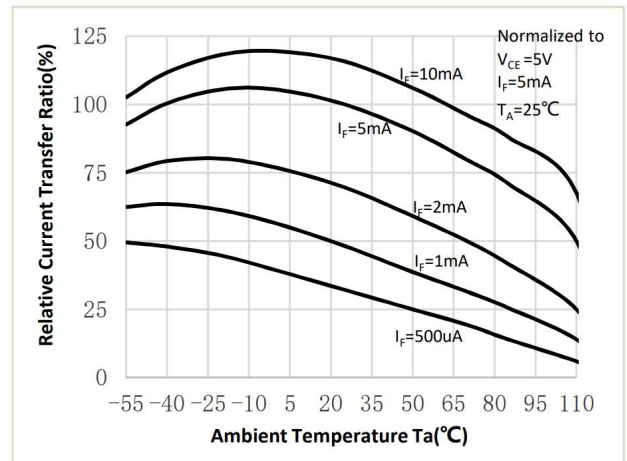

Fig.5 Collector-emitter Saturation Voltage vs. Ambient Temperature

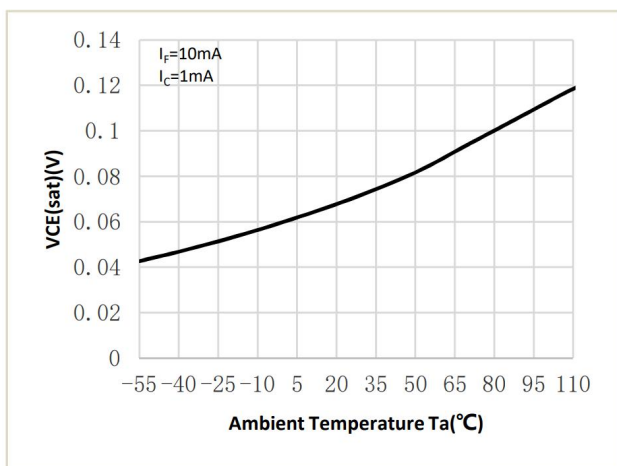
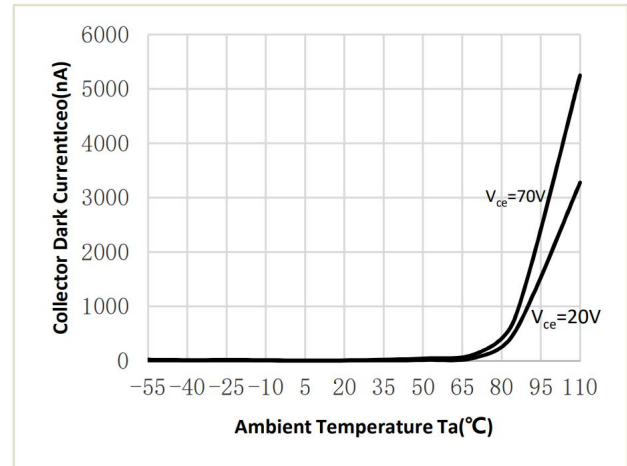

Fig.6 Collector Dark Current vs. Ambient Temperature



Ratings and Characteristics Curves (@ $T_A = 25^\circ\text{C}$ unless otherwise specified)

Fig.7 Response Time vs. Load Resistance

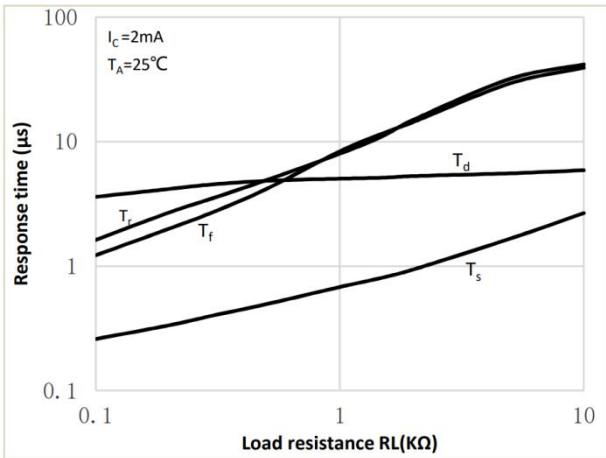

Fig.8 Frequency Response

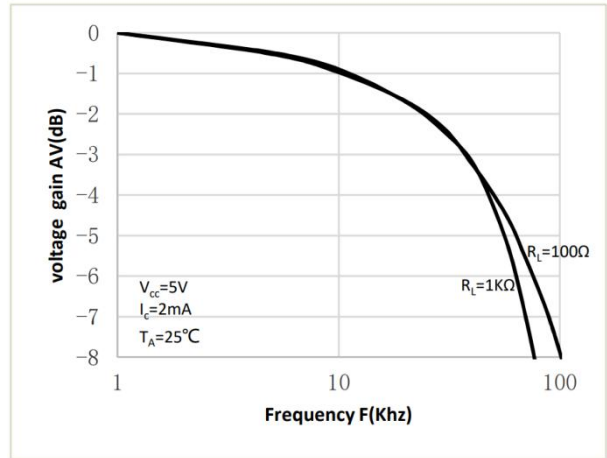

Fig.9 Collector-emitter Saturation Voltage vs. Forward Current

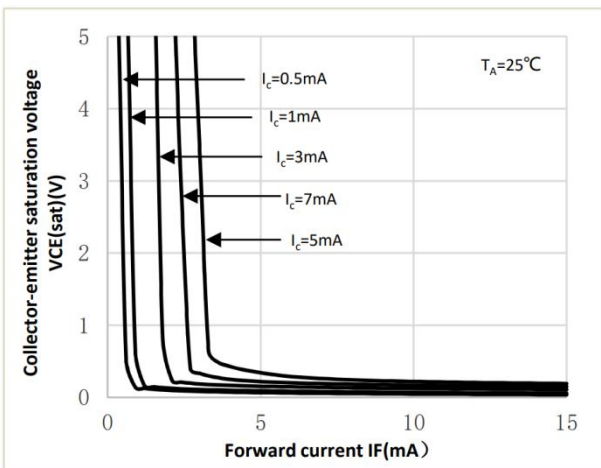
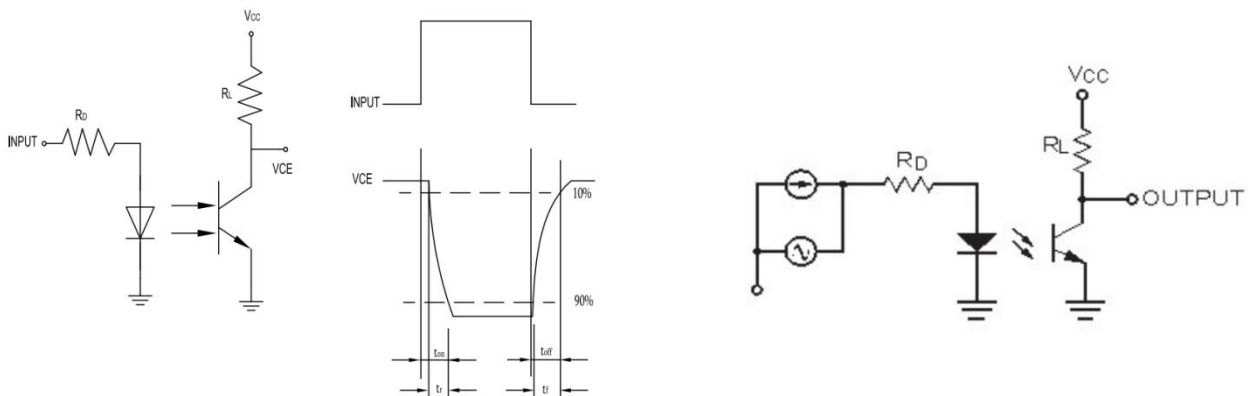
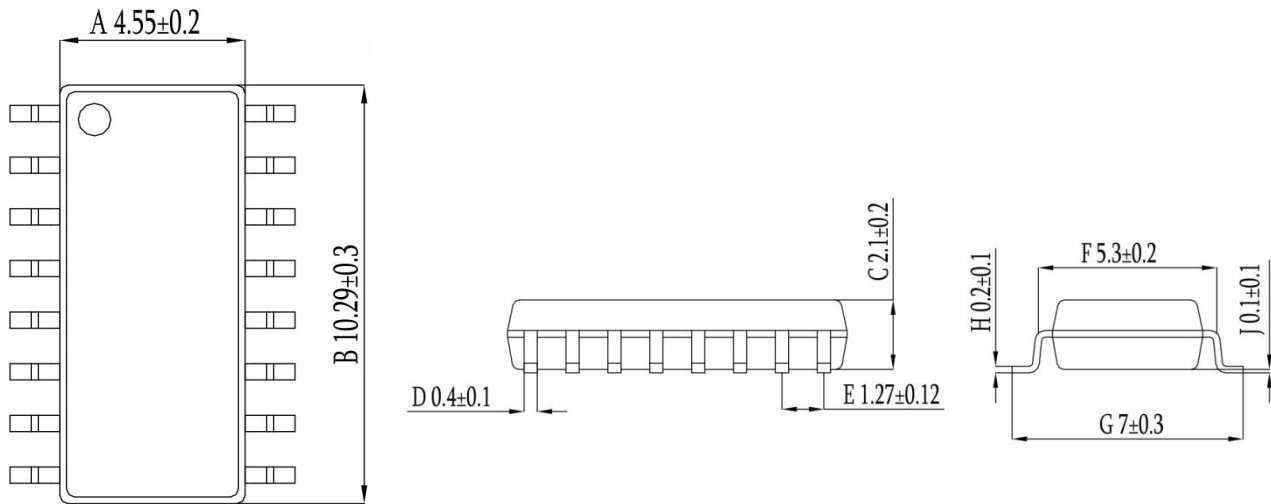

Fig.10 Switching Time Test Circuit & Waveforms



Package Outline Dimensions (unit: mm)

SSOP16



SOLDERING FOOTPRINT (unit: mm)

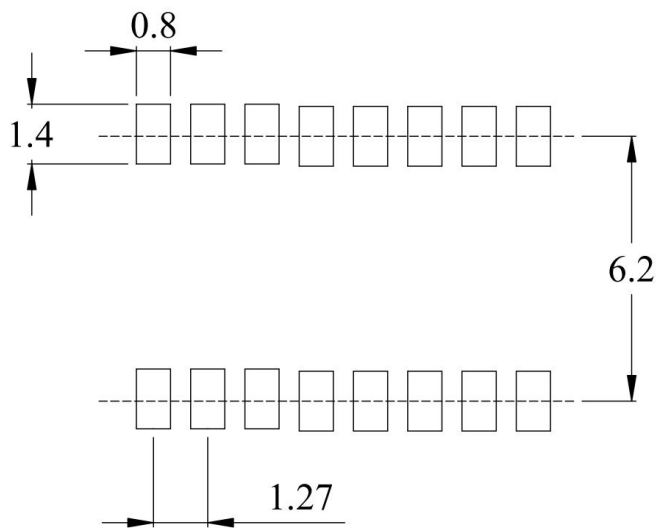

Reflow soldering

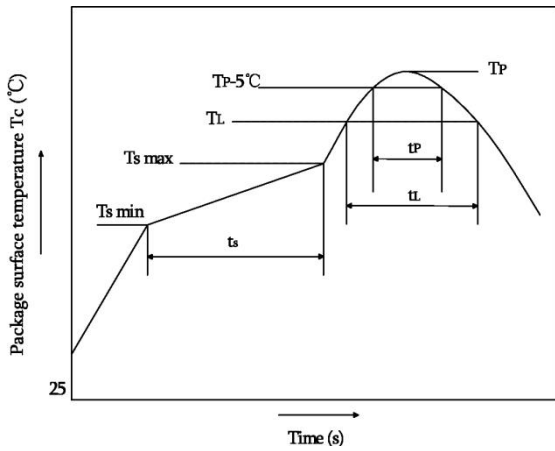

	Symbol	Min	Max	Unit
Preheat temperature	Ts	150	200	°C
Preheat time	ts	60	120	s
Ramp-up rate(T _L to T _P)			3	°C/s
Liquidus temperature	T _L	217		°C
Time above T _L	t _L	60	150	s
Peak temperature	T _P		260	°C
Time during which T _c is between (T _P -5) and T _P	t _p		30	s
Ramp-down rate(T _P to T _L)			6	°C/s

Note:

Reflow soldering is recommended at the temperatures and times shown, no more than three times.

Wave soldering

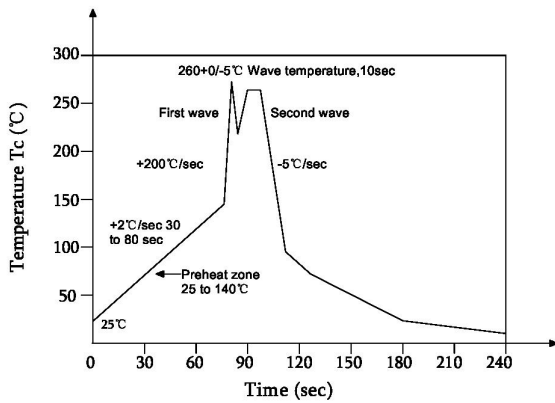

Profile feature	
Average ramp-up rate	~200°C/s
Heating rate during preheat	1°C/s to 2°C/s typical; 4°C/s maximum
Final preheat temperature Ts	~130°C
Preheat time (25°C to Ts)	>60s
Peak temperature Tp	260°C
Time within peak temperature tp	10s
Ramp-down rate	5°C/s maximum

Soldering with hand soldering iron

- A. Hand soldering iron is only used for product rework or sample testing.
- B. Hand soldering iron requirements: Temperature: 360 °C+5°C within 3s.

Packing

Package Type	Packing Form	Quantity per Tube & Reel	Quantity per Box	Quantity per Carton	Antistatic Bag Specification	Box Specification	Carton Specification	Note
SOP16	Reel(Ø330mm)	1000pcs/reel	2reels/box	10 boxes /ctn	380*420mm	350*340*60mm	365*330*370mm	Leave 25 Spaces at the beginning and 50 Spaces at the end

■ Summary table

■ SOP16(reel)

Qty/tube: 1000pcs. Qty/box: 2000pcs.

Qty/ctn: 20000pcs.

Schematic: (unit:mm)

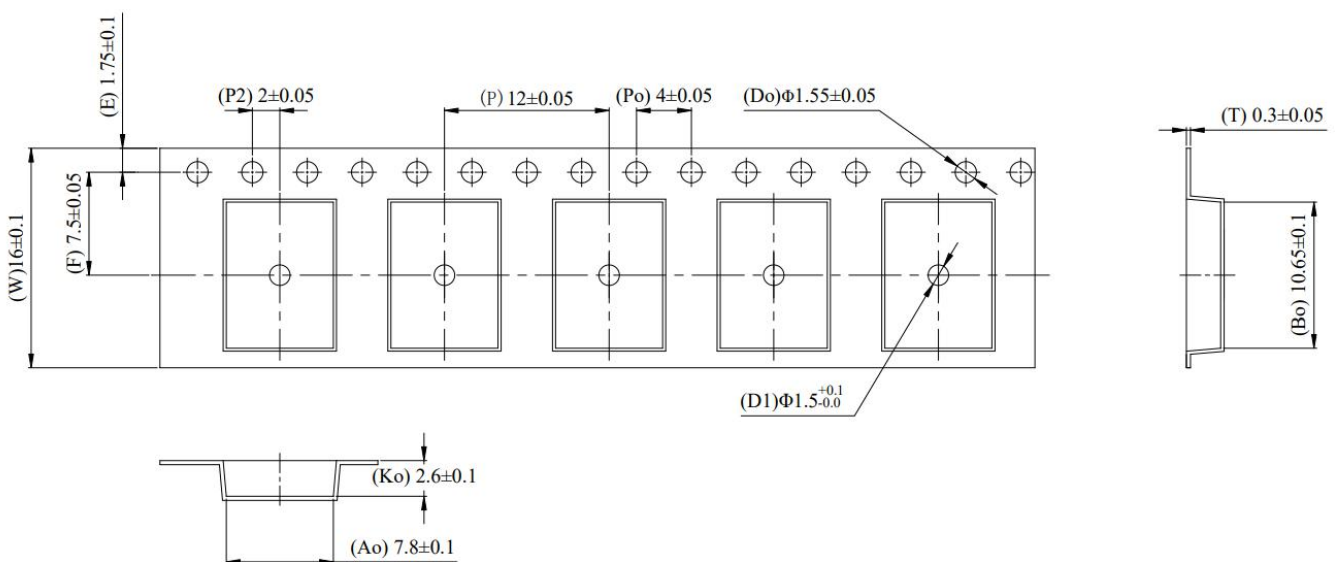

Attention

- XINGLIGHT implements dynamic technical updates. Specifications are subject to change. Refer to the official website for the latest version.
- Users must strictly adhere to specified conditions. Failures caused by misuse (overload, high temperature, incompatible circuits) are excluded from warranty.
- Contact technical support for customized validation in critical applications (medical devices, industrial control).
- This document is valid until Dec 31, 2026. Updates will be notified on the official website.
- For further clarification on technical specifications or application solutions, please contact us through official channels.