

### Product packaging logic diagram

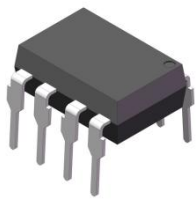

DIP8

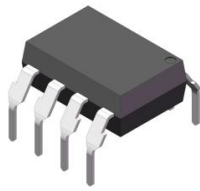

DIP8-M

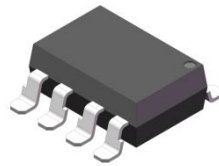

SMD8

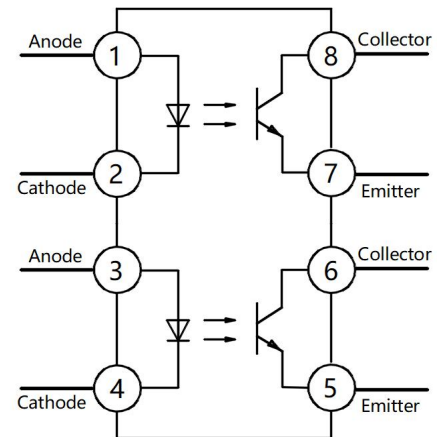

Pin Configuration

### Features

- Current transfer ratio ( CTR: 50~600% at  $I_F = 5\text{mA}$ ,  $V_{CE} = 5\text{V}$  )
- High isolation voltage between input and output ( $V_{iso} = 5000\text{V}_{rms}$  )
- Collector - emitter breakdown voltage  $BV_{CEO} \geq 80\text{V}$
- Operating Temperature:  $-55^\circ\text{C} \sim 110^\circ\text{C}$
- Environmentally friendly products, compliant with CQC, UL, and VDE requirements

### Mechanical Data

- Case: DIP8、DIP8-M、SMD8
- Molding Compound: UL Flammability Classification Rating 94V-0
- Terminals: Matte tin-plated leads; solder ability-per MIL-STD-202, Method 208

### Applications

- It is widely used in the feedback control loop of switching power supply and the isolation between the main circuit and the control circuit, ensuring the stability of the output voltage and quickly transmitting the fault signal to trigger the protection mechanism in the case of overload or short circuit.
- In applications such as PLCs (Programmable Logic Controllers), motor drives, and sensor interfaces, it is used for signal isolation to prevent high-voltage noise from interfering with low-voltage control logic.
- For signal isolation in serial communication interfaces (e.g., RS-232,) to improve anti-interference capability.
- Consumer electronics: household appliances, smart home devices (smart lighting, smart sockets), computers and peripherals (printers, monitors), etc.
- Lighting control: AC transistor optocoupler is suitable for dimming control, smart switching, and wireless control, supporting AC input.



### Ordering Information

XL      827      (X)      (X)      (X) -      (U)      (N)      (Y)  
 ①            ②            ③            ④            ⑤            ⑥            ⑦            ⑧

- ① Brand (XL)
- ② Product series (827)
- ③ Package type (None: (DIP8、DIP8-M、SMD8)
- ④ Halogen option (None : Halogen free)
- ⑤ CTR Bank(A,B,C,D or None)
- ⑥ Lead frame (None: Copper)
- ⑦ Customer option 1 (0-9 or A- Z or none)
- ⑧ Customer option 2 (0-9 or A- Z or none)

Part Number	Package	Shipping Quantity	Marking Code
XL827X	DIP8	45pcs / Tube	XL827X
XL827MX	DIP8-M	45pcs / Tube	XL827X
XL827SX	SMD8	1000pcs / Tape & Reel	XL827X

**Notes** 1: X denotes CTR Rank : A, B or None.

### Marking Information

- " XL" denotes brand.
- " X" denotes CTR Rank : A,B,C,D or None
- " Y" denotes Year : A(2024), B(2025), C(2026)
- " WW" denotes Week' s number .
- " N" denotes the day of Week.

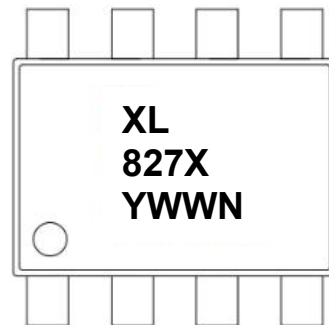

#### Maximum Ratings (@ T<sub>A</sub> = 25°C unless otherwise specified)

Parameter		Symbol	Value	Unit
Input	Forward Current	IF	50	mA
	Peak Forward Current *1	IFM	1	A
	Reverse Voltage	VR	6	V
	Power Dissipation	PD	70	mW
Output	Collector Power Dissipation	PC	150	mW
	Collector Current	IC	50	mA
	Collector-Emitter Voltage	VCEO	80	V
	Emitter-Collector Voltage	VECO	7	V

#### Thermal Characteristics

Parameter	Symbol	Value	Unit
Total Power Dissipation	PTOT	200	mW
Isolation Voltage *2	VISO	5000	Vrms
Rated Impulse Isolation Voltage	VIOTM	6000	V
Rated Repetitive Peak Isolation Voltage	VIORM	630	V
Thermal Resistance Junction-to-Air	R $\theta$ JA	430	°C/W
Thermal Resistance Junction-to-Case	R $\theta$ JC	350	°C/W
Thermal Resistance Junction-to-Lead	R $\theta$ JL	368	°C/W
Operating Temperature	TOPR	-55 ~ +110	°C
Storage Temperature Range	TSTG	-55 ~ +125	°C
Soldering Temperature *3	TSOL	260	°C

#### Notes:

1. Pulse width  $\leq 1\mu\text{s}$ , Duty ratio: 0.001
2. 40 to 60% RH, AC for 1 minute
3. For 10 seconds

### Electrical Characteristics (@ T<sub>A</sub> = 25°C unless otherwise specified)

Parameter		Symbol	Test Condition	Min.	Typ.	Max.	Unit
Input	Forward Voltage	V <sub>F</sub>	I <sub>F</sub> = 20mA	-	1.2	1.4	V
	Peak Forward Voltage	V <sub>FM</sub>	I <sub>FM</sub> = 0.5A	-	-	3.0	V
	Reverse Current	I <sub>R</sub>	V <sub>R</sub> = 4V	-	-	10	μA
	Input Capacitance	C <sub>in</sub>	V <sub>R</sub> = 0V, f = 1kHz	-	30	250	pF
Output	Collector-Emitter Dark Current	I <sub>CEO</sub>	V <sub>CE</sub> = 20V, I <sub>F</sub> = 0	-	-	100	nA
	Collector-Emitter Breakdown Voltage	BV <sub>CEO</sub>	I <sub>C</sub> = 0.1mA, I <sub>F</sub> = 0	80	-	-	V
	Emitter-Collector Breakdown Voltage	BV <sub>ECO</sub>	I <sub>E</sub> = 10μA, I <sub>F</sub> = 0	7	-	-	V
Transfer Characteristics	Collector Current	I <sub>C</sub>	I <sub>F</sub> = 5mA, V <sub>CE</sub> = 5V	2.5	-	30	mA
	Current Transfer Ratio	CTR	I <sub>F</sub> = 5 mA, V <sub>CE</sub> = 5V	50	-	600	%
	Collector-Emitter Saturation Voltage	V <sub>CE(sat)</sub>	I <sub>F</sub> = 20mA, I <sub>C</sub> = 1mA	-	0.1	0.2	V
	Isolation Resistance	R <sub>IO</sub>	V <sub>IO</sub> = 500Vdc 40~60% R.H.	1×10 <sup>12</sup>	-	-	Ω
	Isolation current	R <sub>isc</sub>	DC6000V,40~60%R.H	-	-	2	μA
	Floating Capacitance	C <sub>IO</sub>	V <sub>IO</sub> = 0, f = 1MHz	-	0.6	1.0	pF
	Cut-off frequency	f <sub>C</sub>	V <sub>CE</sub> = 5V, I <sub>C</sub> = 2mA R <sub>L</sub> =100Ω, -3dB	-	80	-	kHz
	Turn On Time	T <sub>on</sub>	V <sub>CE</sub> =2V, R <sub>L</sub> = 100Ω I <sub>C</sub> =2mA	-	4	18	μs
Turn Off Time	T <sub>off</sub>	-		3	18		

### Rank Table of Current Transfer Ratio CTR

Rank Mark	Min. (%)	Max. (%)	Condition
A	80	160	I <sub>F</sub> = 5 mA, V <sub>CE</sub> = 5V
B	130	260	
C	200	400	
D	300	600	
No mark	50	600	

### Ratings and Characteristics Curves (@ $T_A = 25^\circ\text{C}$ unless otherwise specified)

Fig.1 Allowable Forward Current vs. Ambient Temperature

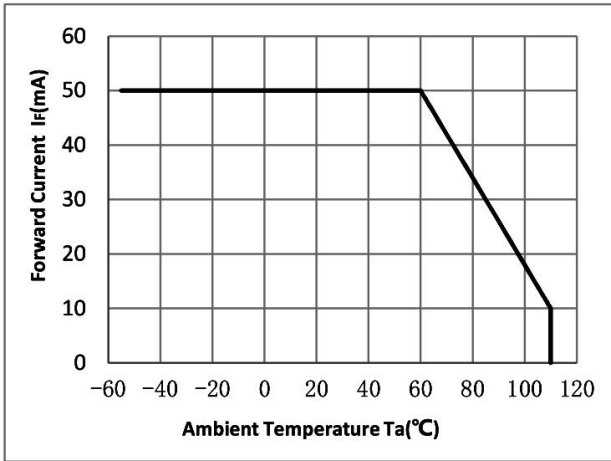

Fig.2 Allowable collector power dissipation vs. Ambient Temperature(°C)

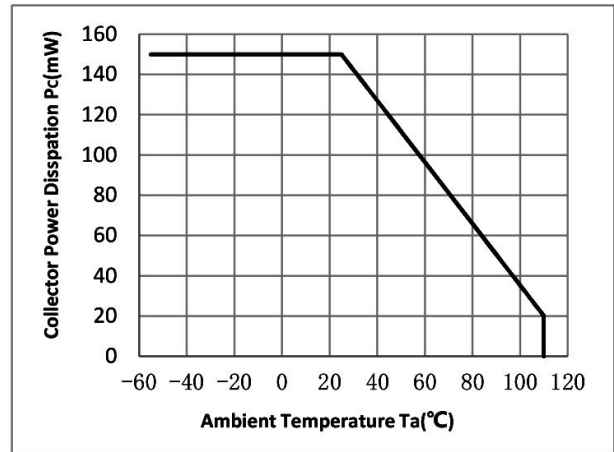

Fig.3 Relative Current Transfer Ratio vs. Forward Current

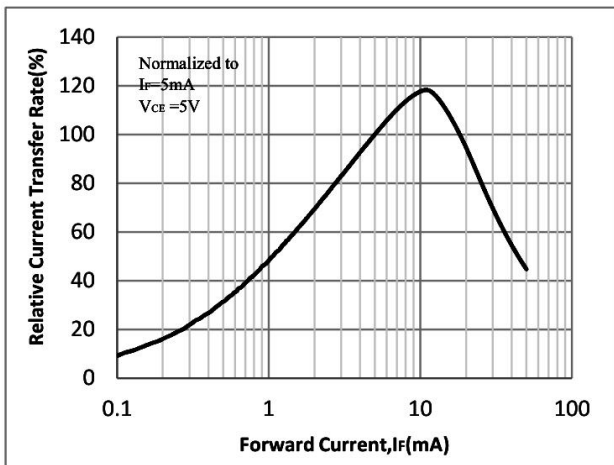

Fig.4 Forward Current vs. Forward Voltage

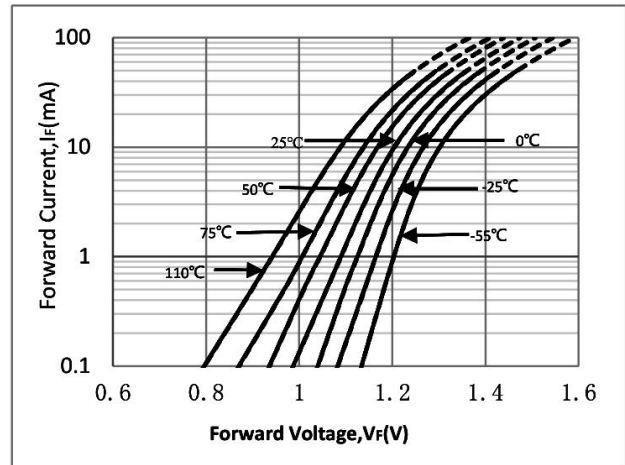

Fig.5 Collector Current vs. Collector-emitter Voltage

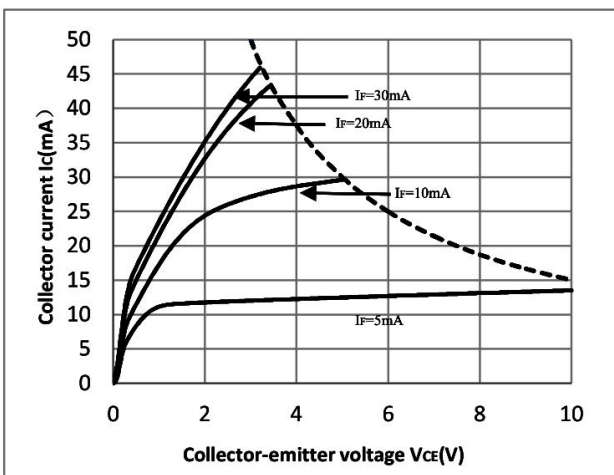
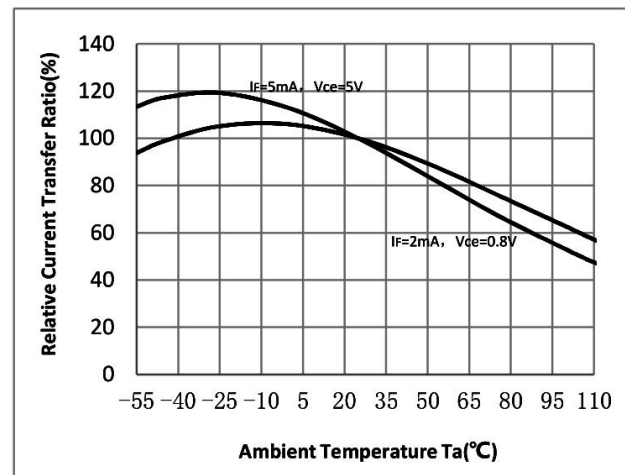

Fig.6 Relative Current Transfer Ratio vs. Ambient Temperature



## Ratings and Characteristics Curves (@ $T_A = 25^\circ\text{C}$ unless otherwise specified)

Fig.7 Collector-emitter Saturation Voltage vs. Ambient Temperature

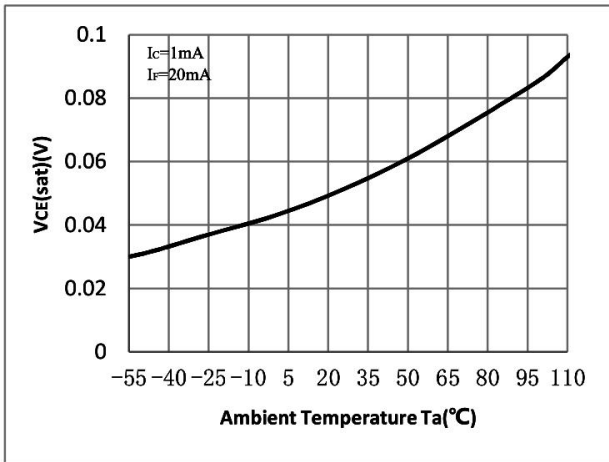

Fig.8 Collector Dark Current vs. Ambient Temperature

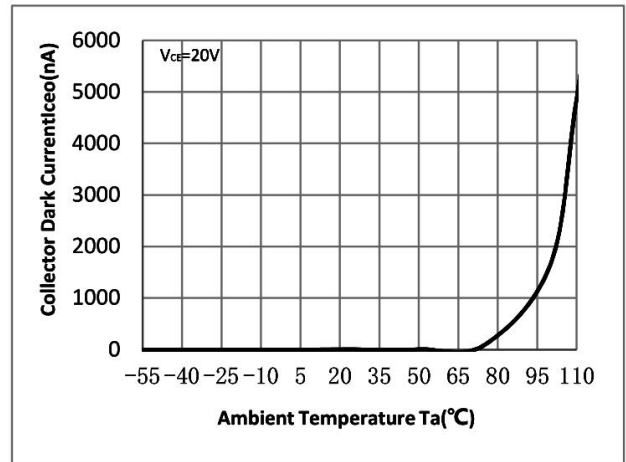

Fig.9 Response Time vs. Load Resistance

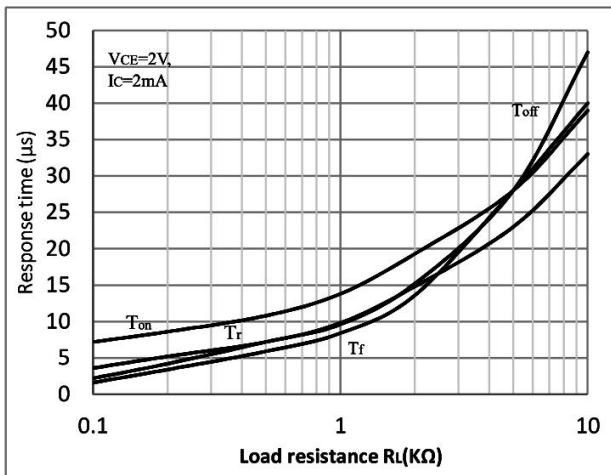

Fig.10 Frequency Response

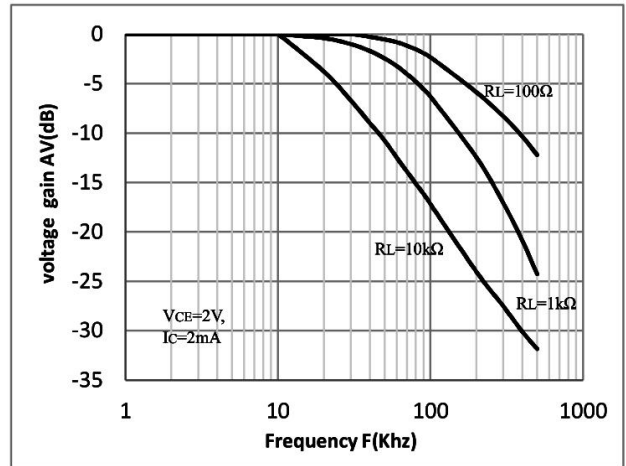

Fig.11 Collector-emitter Saturation Voltage vs. Forward Current

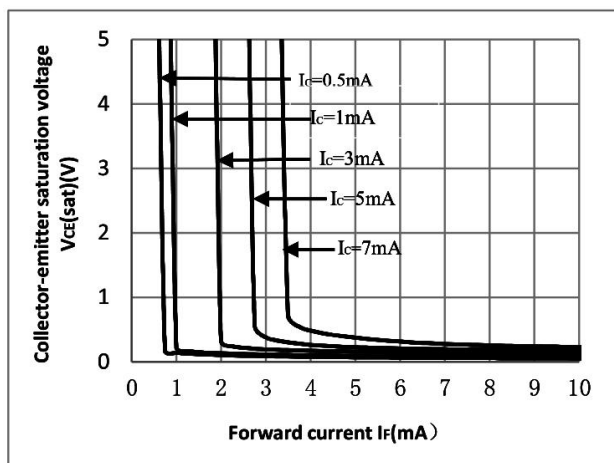
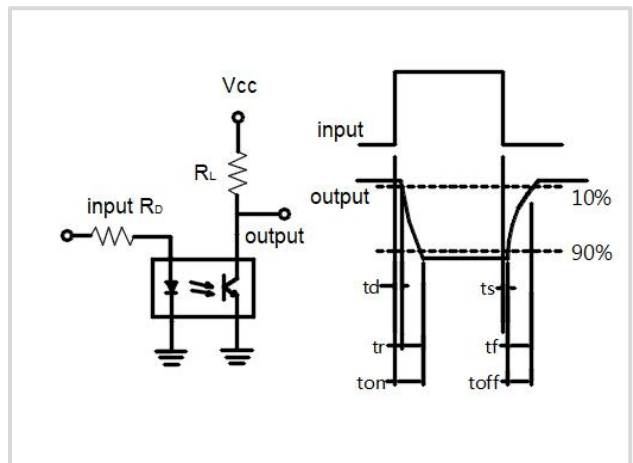
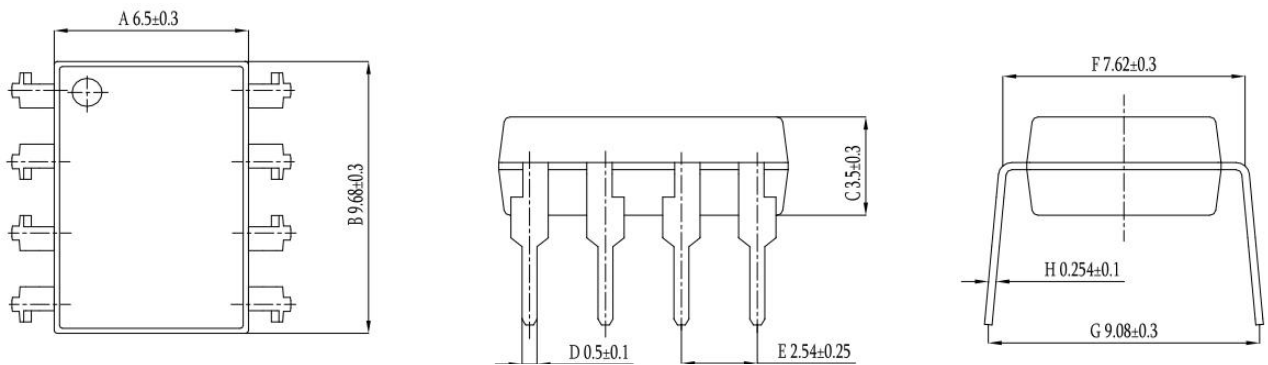

Fig.12 Switching Time Test Circuit & Waveforms



#### Package Outline Dimensions (unit: mm)

##### DIP8



##### DIP8-M

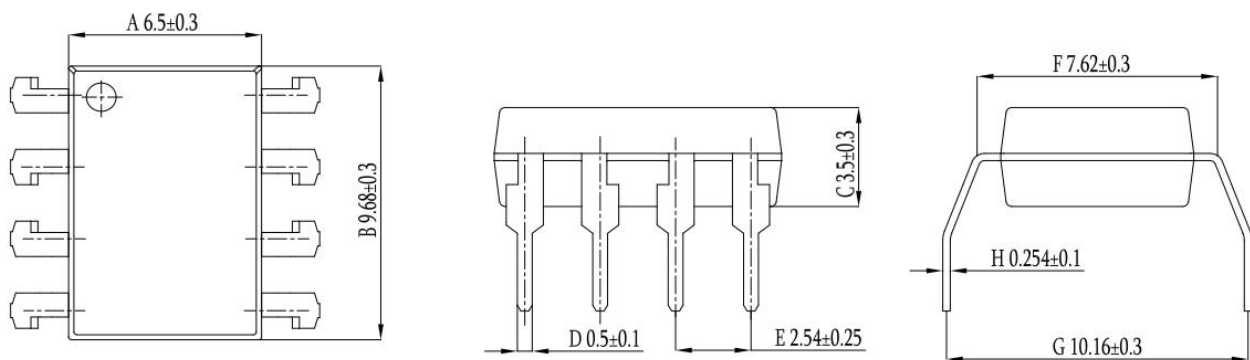

##### SMD8

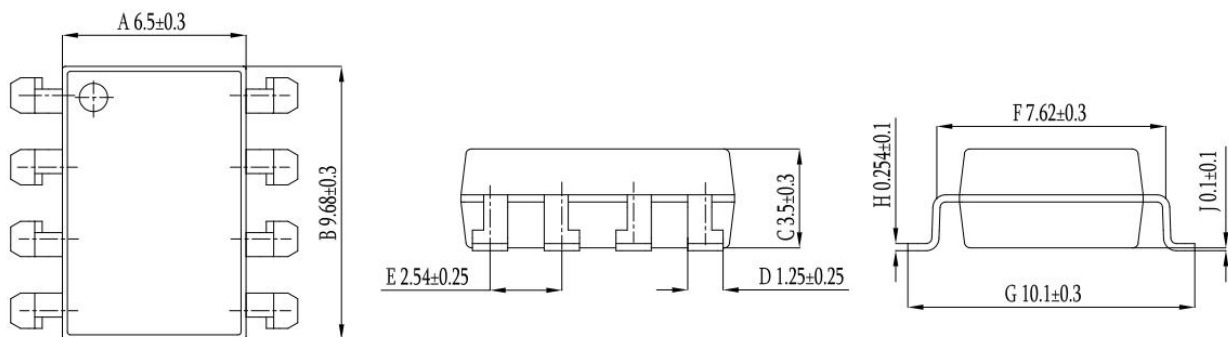

#### SOLDERING FOOTPRINT (unit: mm)

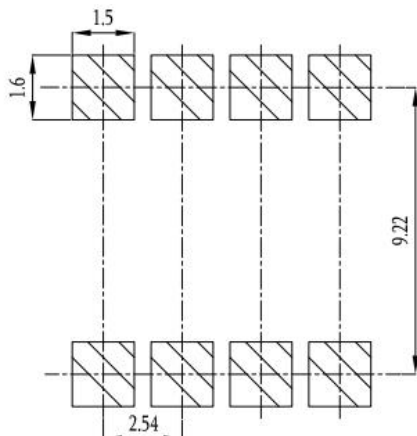

### Reflow soldering

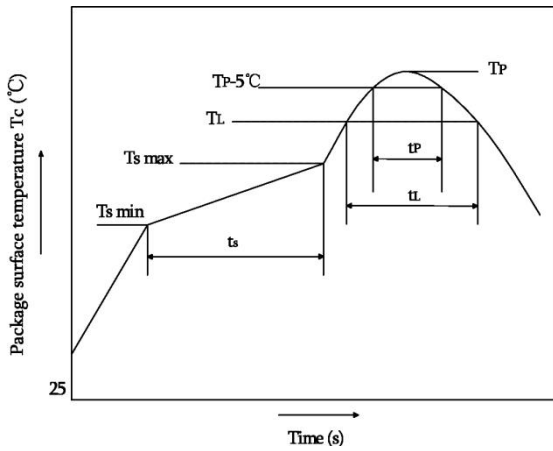

	Symbol	Min	Max	Unit
Preheat temperature	Ts	150	200	°C
Preheat time	ts	60	120	s
Ramp-up rate(T <sub>L</sub> to T <sub>P</sub> )			3	°C/s
Liquidus temperature	T <sub>L</sub>	217		°C
Time above T <sub>L</sub>	t <sub>L</sub>	60	150	s
Peak temperature	T <sub>P</sub>		260	°C
Time during which T <sub>c</sub> is between (T <sub>P</sub> -5) and T <sub>P</sub>	t <sub>p</sub>		30	s
Ramp-down rate(T <sub>P</sub> to T <sub>L</sub> )			6	°C/s

**Note:**

Reflow soldering is recommended at the temperatures and times shown, no more than three times.

### Wave soldering

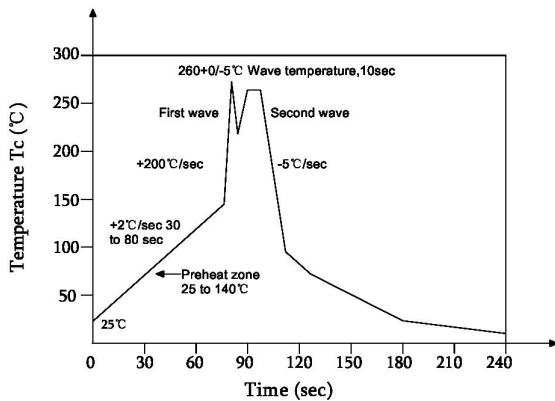

Profile feature	
Average ramp-up rate	~200°C/s
Heating rate during preheat	1°C/s to 2°C/s typical; 4°C/s maximum
Final preheat temperature Ts	~130°C
Preheat time (25°C to Ts)	>60s
Peak temperature Tp	260°C
Time within peak temperature tp	10s
Ramp-down rate	5°C/s maximum

### Soldering with hand soldering iron

- A. Hand soldering iron is only used for product rework or sample testing.
- B. Hand soldering iron requirements: Temperature: 360 °C±5°C within 3s.

### Packing

Package Type	Packing Form	Quantity per Tube & Reel	Quantity per Box	Quantity per Carton	Antistatic Bag Specification	Box Specification	Carton Specification	Note
DIP8	Tube(500mm)	45pcs/tube	50 tubes /box	10 boxes /ctn	190*670mm	520*105*50mm	545*372*235mm	Straight insert type material tube
DIP8-M	Tube(500mm)	45pcs/tube	50 tubes /box	10 boxes /ctn	190*670mm	520*105*50mm	545*372*235mm	Seagull foot (M foot) tube
SMD8	Reel(φ330mm)	1000pcs/reel	2 reels /box	10 boxes /ctn	380*420mm	350*340*60mm	365*330*370mm	Guard band 200mm /min.

#### ■ Summary table

##### ■ DIP8/DIP8-M (Tube)

Qty/tube: 45pcs. Qty/box: 2250pcs.

Qty/ctn: 22500pcs.

Schematic: (unit:mm)

##### ■ SMD8 (Reel)

Qty/reel: 1000pcs. Qty/box: 2000pcs.

Qty/ctn: 20000pcs.

Schematic: (unit:mm)

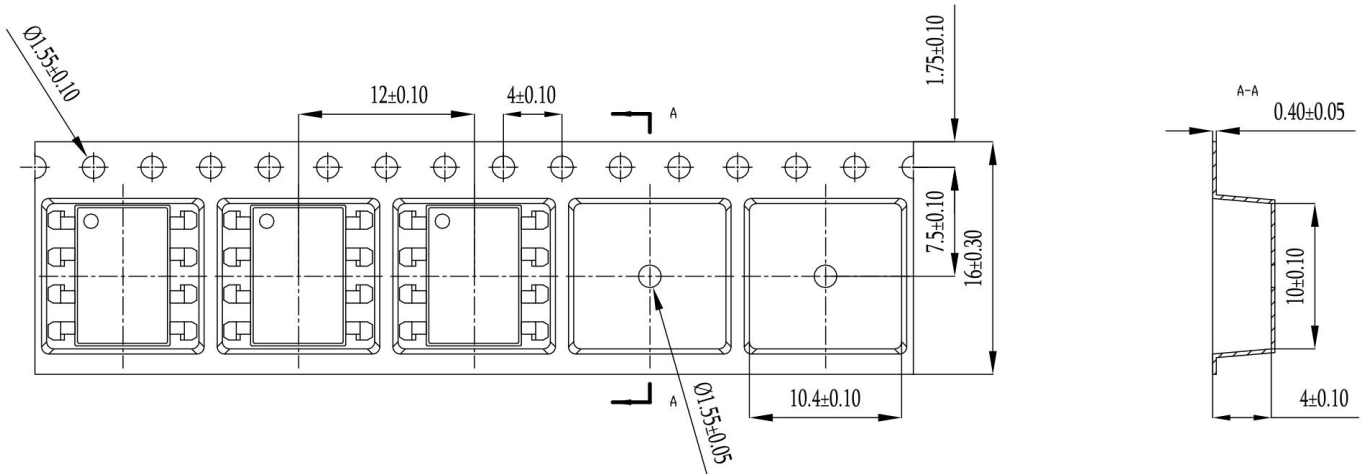

**Attention**

- XINGLIGHT implements dynamic technical updates. Specifications are subject to change. Refer to the official website for the latest version.
- Users must strictly adhere to specified conditions. Failures caused by misuse (overload, high temperature, incompatible circuits) are excluded from warranty.
- Contact technical support for customized validation in critical applications (medical devices, industrial control).
- This document is valid until Dec 31, 2026. Updates will be notified on the official website.
- For further clarification on technical specifications or application solutions, please contact us through official channels.