

Product packaging logic diagram

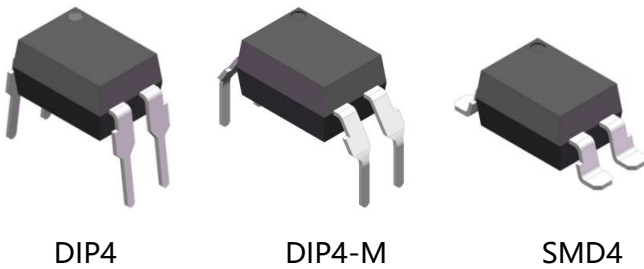

DIP4

DIP4-M

SMD4

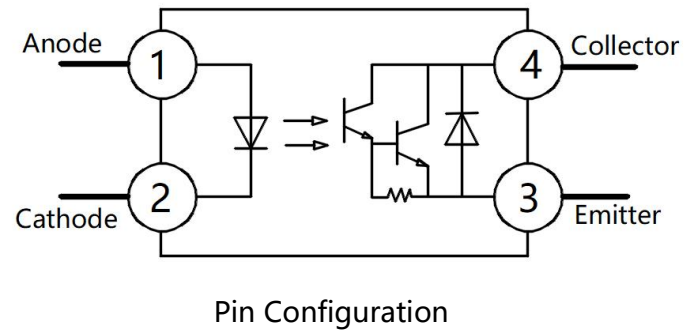

Features

- Current transfer ratio (CTR: $\geq 1000\%$ at $I_F = 1\text{mA}$, $V_{CE} = 2\text{V}$)
- High isolation voltage between input and output ($V_{iso} = 5000\text{Vrms}$)
- Operating Temperature: $-55^\circ\text{C} \sim 110^\circ\text{C}$
- Environmentally friendly products, compliant with CQC, UL, and VDE requirements

Mechanical Data

- Case: DIP4、DIP4-M、SMD4
- Molding Compound: UL Flammability Classification Rating 94V-0
- Terminals: Matte tin-plated leads; solder ability-per MIL-STD-202, Method 208

Applications

- It is widely used in the feedback control loops of switching power supplies and the isolation between main circuits and control circuits, ensuring stable output voltage and quickly transmitting fault signals to trigger protection mechanisms in the event of overload or short circuit.
- Photovoltaic energy storage system
- Data collection, inverter control, protection circuit
- Industrial automation control
- Relay drive, motor control, PLC interface
- Power management
- Switching power supply feedback isolation、Home appliance power control



Ordering Information

XL 852 (X) (X) (X) - (U) (N) (Y)
 ① ② ③ ④ ⑤ ⑥ ⑦ ⑧

- ① Brand (XL)
- ② Product series (852)
- ③ Package type(None: (DIP4、 DIP4-M、 SMD4)
- ④ Halogen option(None : Halogen free)
- ⑤ CTR Bank(None:≥1000%)
- ⑥ Lead frame (None: Copper)
- ⑦ Customer option 1 (0-9 or A- Z or none)
- ⑧ Customer option 2 (0-9 or A- Z or none)

Part Number	Package	Shipping Quantity	Marking Code
XL852	DIP4	100pcs / Tube	XL852
XL852M	DIP4-M	100pcs / Tube	XL852
XL852S	SMD4	2000pcs / Tape & Reel	XL852

Notes 1: X denotes CTR Rank : A, B or None.

Marking Information

- " XL" denotes brand.
- " 852" denotes Product series.
- " Y" denotes Year : A(2024), B(2025), C(2026)
- " WW" denotes Week' s number .
- " N" denotes the day of Week.



Maximum Ratings (@ T_A = 25°C unless otherwise specified)

Parameter		Symbol	Value	Unit
Input	Forward Current	I _F	60	mA
	Peak Forward Current *1	I _{FM}	1	A
	Reverse Voltage	V _R	6	V
	Power Dissipation	P _D	100	mW
Output	Collector Power Dissipation	P _C	150	mW
	Collector Current	I _C	150	mA
	Collector-Emitter Voltage	V _{CEO}	350	V
	Emitter-Collector Voltage	V _{ECO}	0.1	V

Thermal Characteristics

Parameter	Symbol	Value	Unit
Total Power Dissipation	PTOT	250	mW
Isolation Voltage *2	VISO	5000	V _{rms}
Operating Temperature	TOPR	-55 ~ +110	°C
Storage Temperature Range	TSTG	-55 ~ +125	°C
Soldering Temperature *3	TSOL	260	°C

Notes:

1. Pulse width ≤ 1μs, Duty ratio: 0.001
2. 40 to 60% RH, AC for 1 minute
3. For 10 seconds

Electrical Characteristics (@ T_A = 25°C unless otherwise specified)

Parameter		Symbol	Test Condition	Min.	Typ.	Max.	Unit
Input	Forward Voltage	V _F	I _F = 10mA	-	1.2	1.4	V
	Reverse Current	I _R	V _R = 4V	-	-	10	μA
	Input Capacitance	C _{in}	V _R = 0V, f = 1kHz	-	50	-	pF
Output	Collector-Emitter Dark Current	I _{CEO}	V _{CE} = 200V	-	-	100	nA
	Collector-Emitter Breakdown Voltage	BV _{CEO}	I _C = 0.1mA, I _F = 0	350	-	-	V
	Emitter-Collector Breakdown Voltage	BV _{ECO}	I _E = 10μA, I _F = 0	0.1	-	-	V
Transfer Characteristics	Current Transfer Ratio	CTR	I _F = 1 mA, V _{CE} = 2V	1000	-	-	%
	Collector-Emitter Saturation Voltage	V _{CE(sat)}	I _F = 20mA, I _C = 100mA	-	1.2	1.5	V
	Isolation Resistance	R _{ISO}	V _{IO} = 500Vdc 40~60% R.H.	5×10 ¹⁰	1×10 ¹¹	-	Ω
	Floating Capacitance	C _{IO}	V _{IO} = 0, f = 1MHz	-	0.6	-	pF
	Cut-off frequency	f _c	V _{CE} = 2V, I _C = 2mA R _L =100Ω, -3dB	-	7	-	kHz
	Turn On Time	T _{on}	V _{CE} =2V, R _L = 100Ω I _C =20mA	-	80	250	μs
	Turn Off Time	T _{off}		-	10	100	

Ratings and Characteristics Curves (@ $T_A = 25^\circ\text{C}$ unless otherwise specified)

Fig.1 Collector-Emitter Saturation Voltage vs. Ambient Temperature

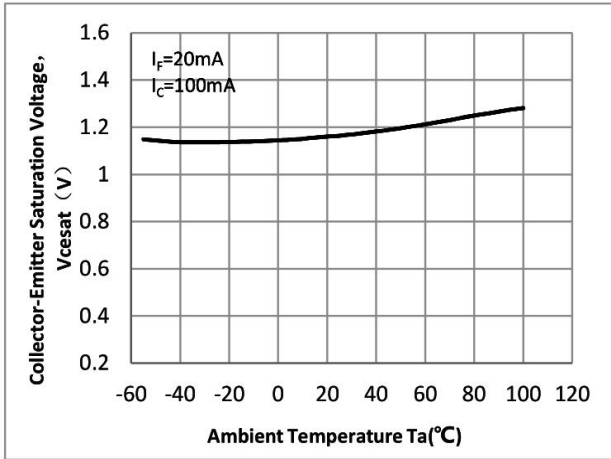

Fig.2 Forward Current vs. Forward Voltage

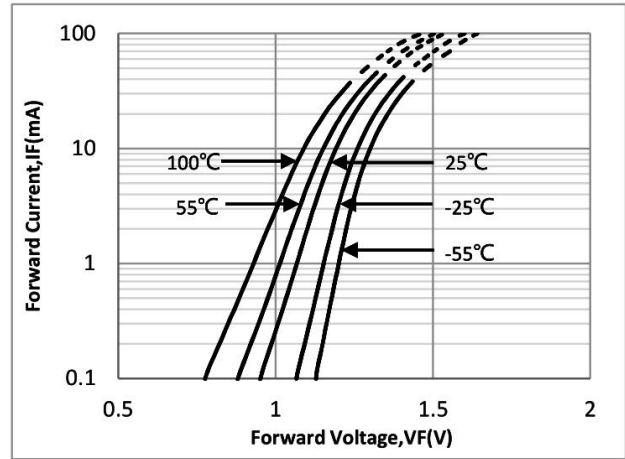

Fig.3 Current Transfer Ratio vs. Forward Current

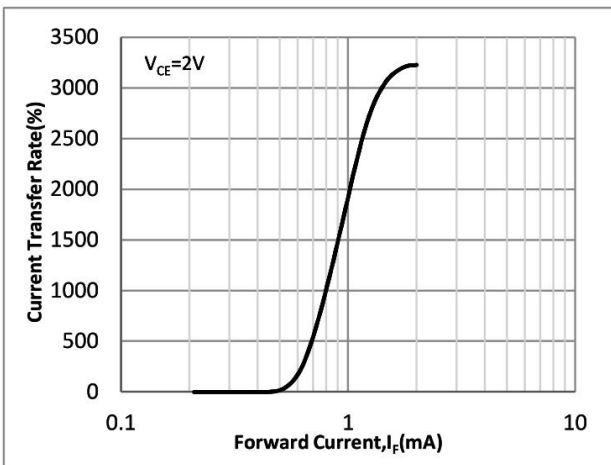

Fig.4 Relative Current Transfer Ratio vs. Ambient Temperature

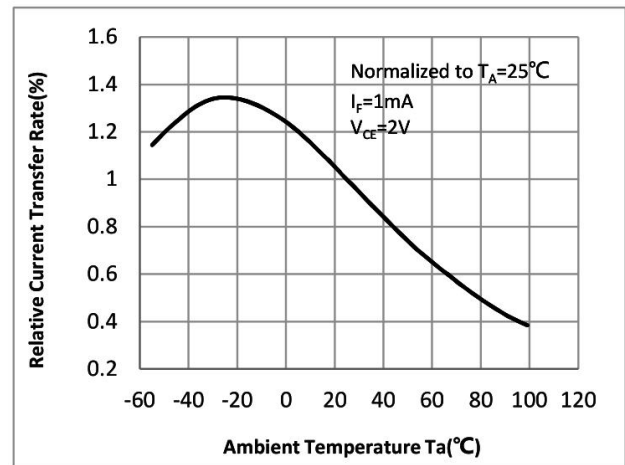

Fig.5 Collector-Emitter Dark Current vs. Ambient Temperature

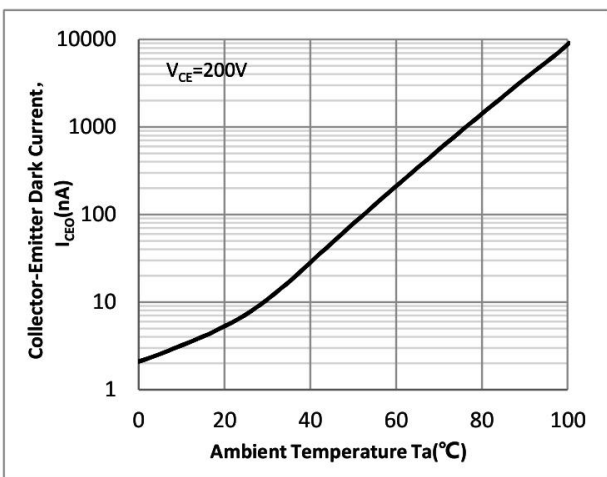
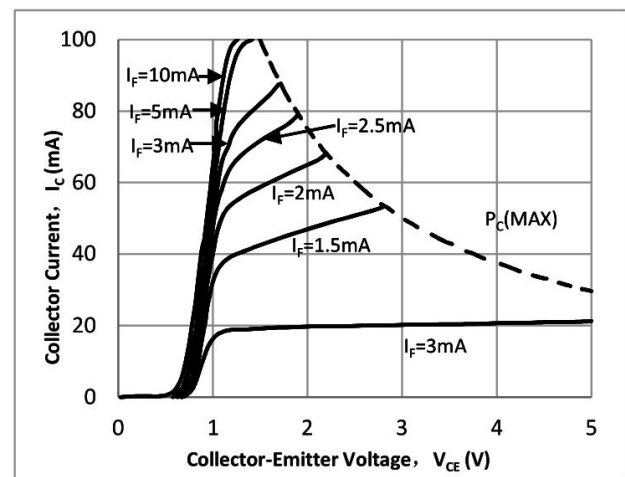

Fig.6 Collector Current vs. Collector-Emitter Voltage



Ratings and Characteristics Curves (@ $T_A = 25^\circ\text{C}$ unless otherwise specified)

Fig.7 Response time vs. Load resistor

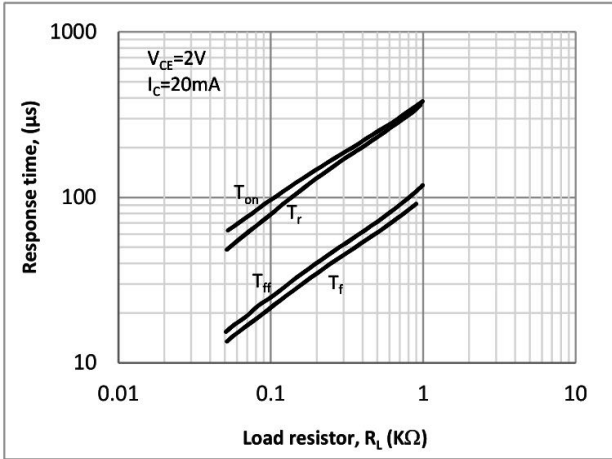

Fig.8 Forward Current vs. Collector-Emitter Saturation Voltage,

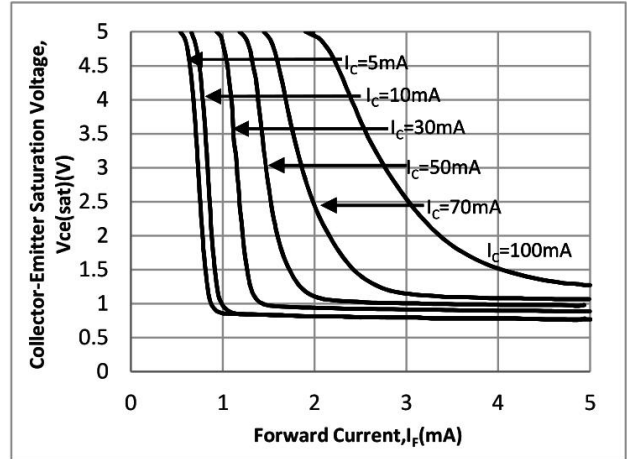

Fig.9 Frequency response

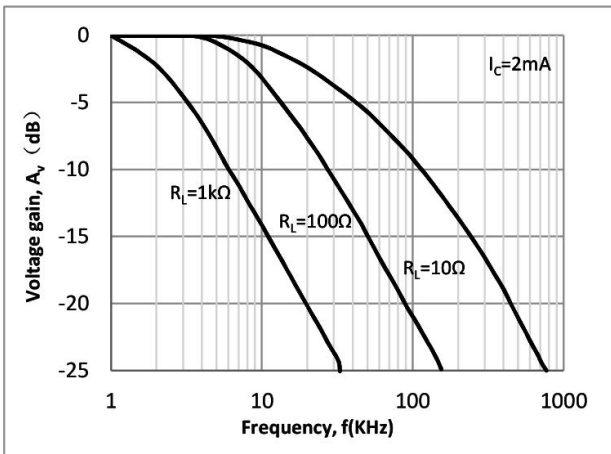
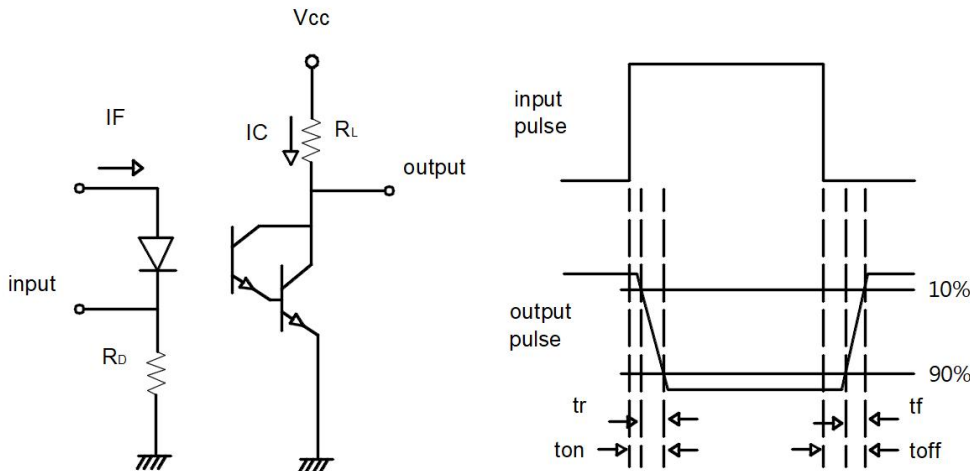
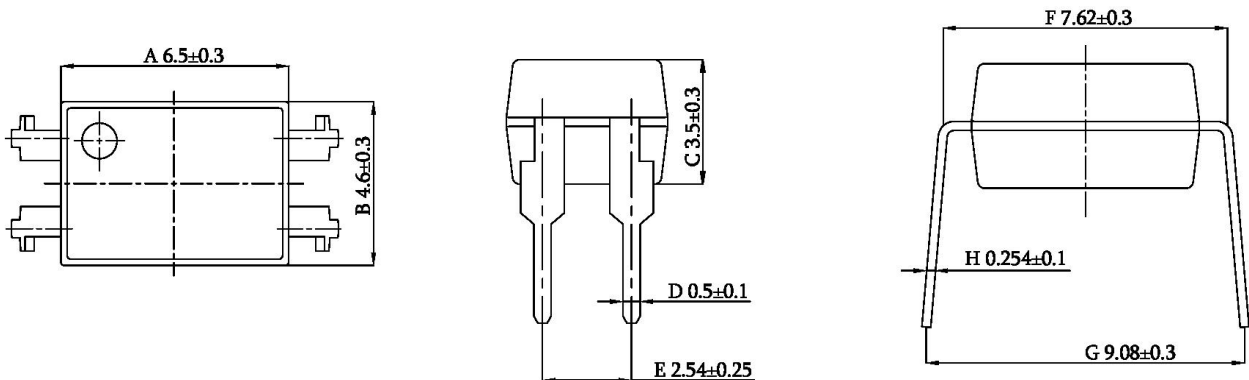

Fig.10 Switching Time Test Circuit & Wave forms



Package Outline Dimensions (unit: mm)

DIP4



DIP4-M

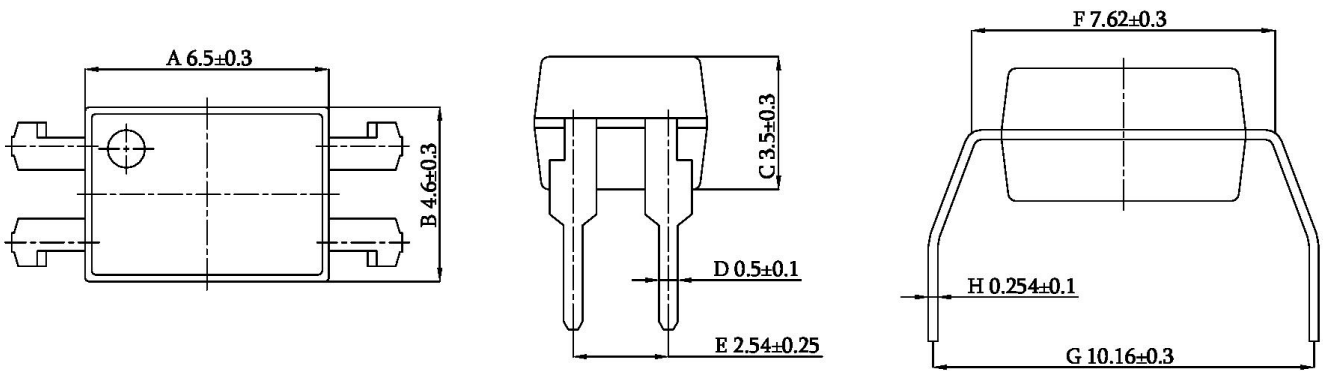

SMD4

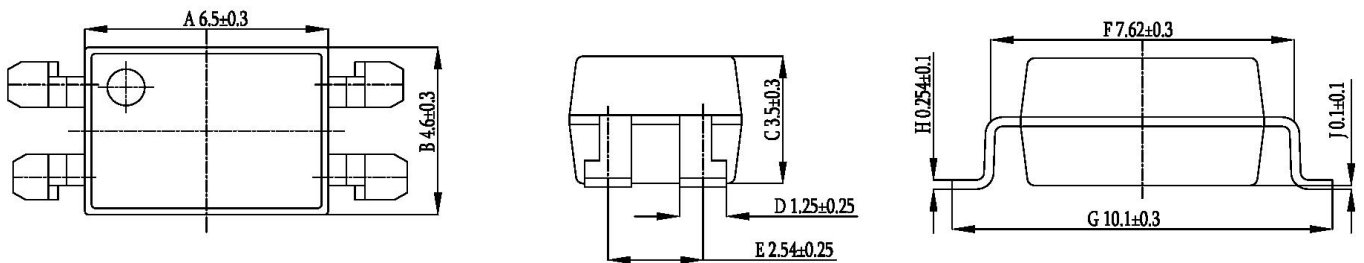

SOLDERING FOOTPRINT (unit: mm)

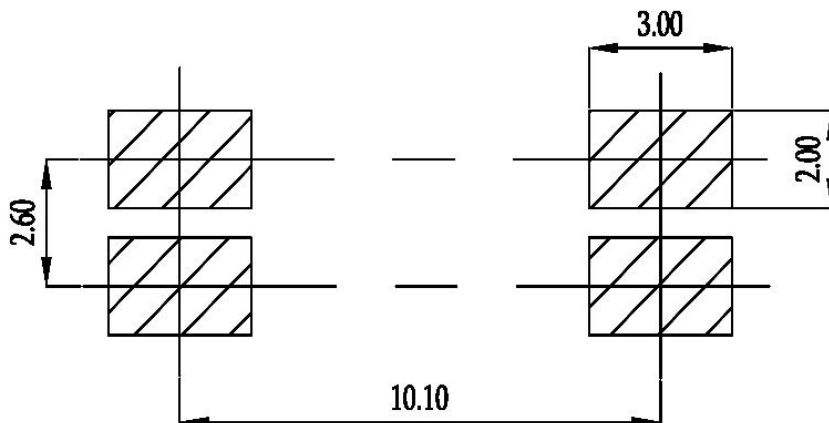

Reflow soldering

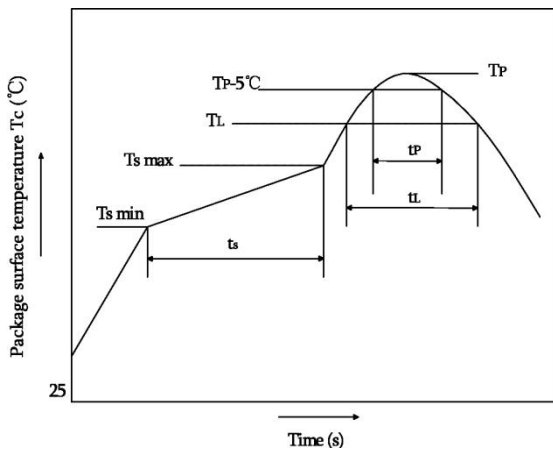

	Symbol	Min	Max	Unit
Preheat temperature	Ts	150	200	°C
Preheat time	ts	60	120	s
Ramp-up rate(T _L to T _P)			3	°C/s
Liquidus temperature	T _L	217		°C
Time above T _L	t _L	60	150	s
Peak temperature	T _P		260	°C
Time during which T _c is between (T _P -5) and T _P	t _p		30	s
Ramp-down rate(T _P to T _L)			6	°C/s

Note:

Reflow soldering is recommended at the temperatures and times shown, no more than three times.

Wave soldering

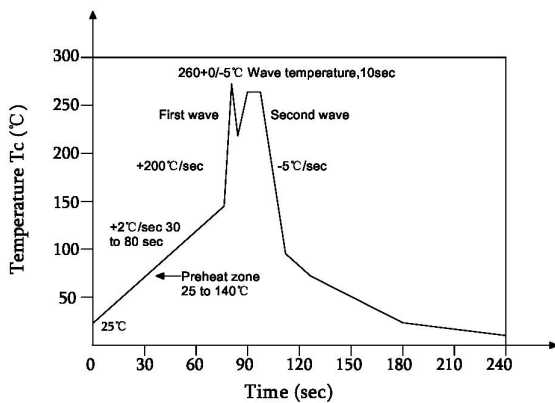

Profile feature	
Average ramp-up rate	~200°C/s
Heating rate during preheat	1°C/s to 2°C/s typical; 4°C/s maximum
Final preheat temperature Ts	~130°C
Preheat time (25°C to Ts)	>60s
Peak temperature T _p	260°C
Time within peak temperature t _p	10s
Ramp-down rate	5°C/s maximum

Soldering with hand soldering iron

- A. Hand soldering iron is only used for product rework or sample testing.
- B. Hand soldering iron requirements: Temperature: 360 °C+5°C within 3s.

Packing

Package Type	Packing Form	Quantity per Tube & Reel	Quantity per Box	Quantity per Carton	Antistatic Bag Specification	Box Specification	Carton Specification	Note
DIP4	Tube(500mm)	100pcs/tube	50 tubes /box	10 boxes /ctn	190*670mm	520*105*50mm	545*372*235mm	Straight insert type material tube
DIP4-M	Tube(500mm)	100pcs/tube	50 tubes /box	10 boxes /ctn	190*670mm	520*105*50mm	545*372*235mm	Seagull foot (M foot) tube
SMD4	Reel(φ330mm)	2000pcs/reel	2 reels /box	10 boxes /ctn	380*420mm	350*340*60mm	365*330*370mm	Guard band 200mm /min.

■ Summary table

■ DIP4/DIP4-M (Tube)

Qty/ tube: 100pcs. Qty/box: 5000pcs.

Qty/ctn: 50000pcs.

Schematic: (unit:mm)

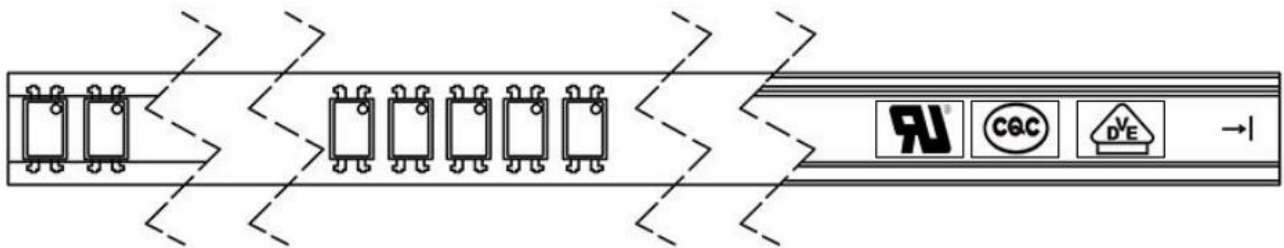

■ SMD4 (Reel)

Qty/reel: 2000pcs. Qty/box: 4000pcs.

Qty/ctn: 40000pcs.

Schematic: (unit:mm)

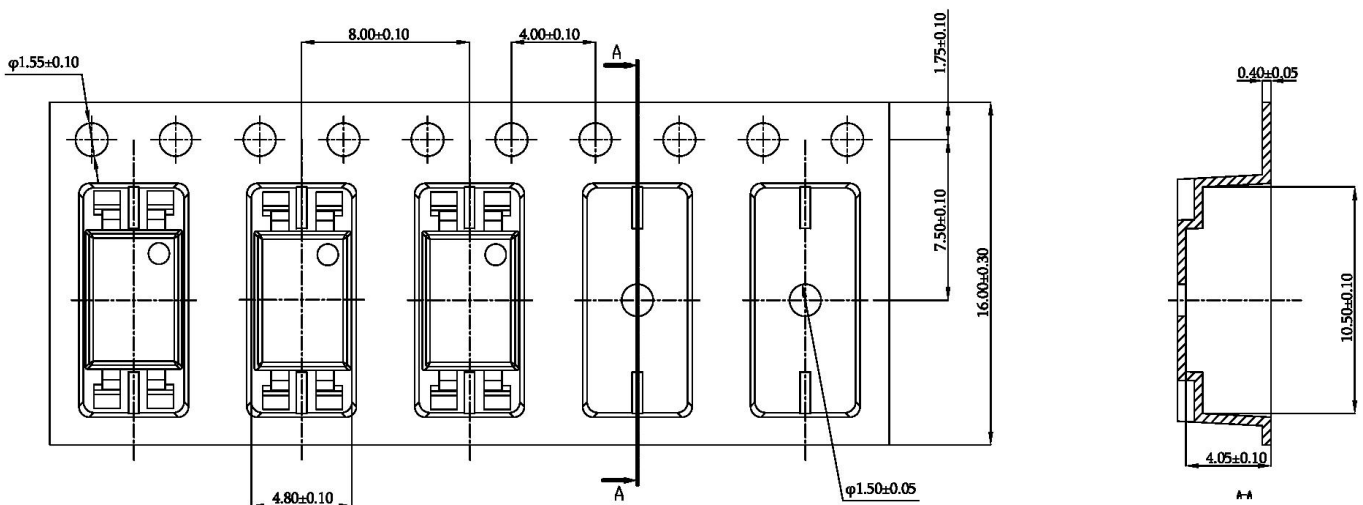

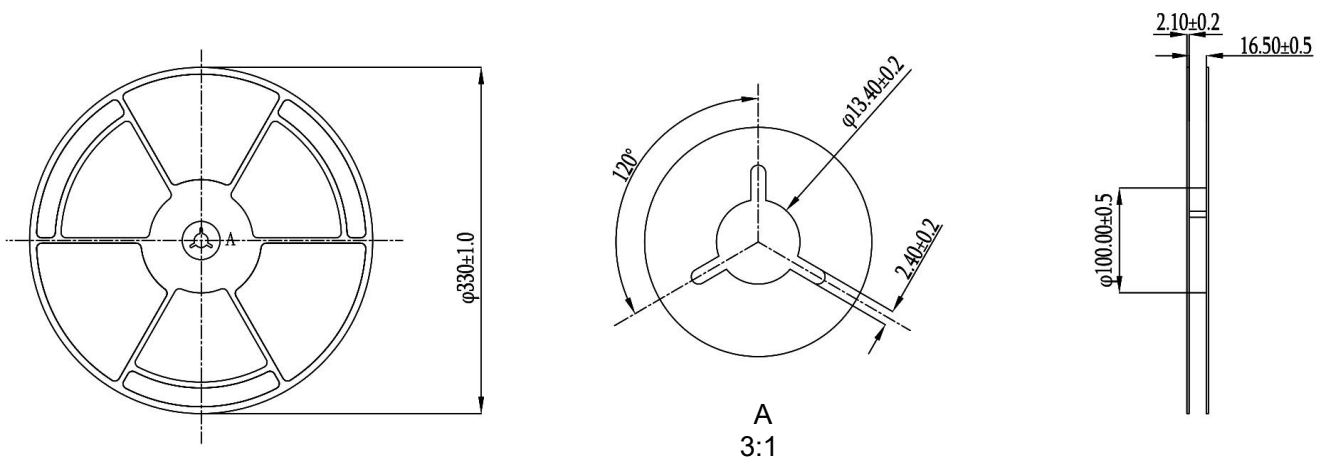

Attention

- XINGLIGHT implements dynamic technical updates. Specifications are subject to change. Refer to the official website for the latest version.
- Users must strictly adhere to specified conditions. Failures caused by misuse (overload, high temperature, incompatible circuits) are excluded from warranty.
- Contact technical support for customized validation in critical applications (medical devices, industrial control).
- This document is valid until Dec 31, 2026. Updates will be notified on the official website.
- For further clarification on technical specifications or application solutions, please contact us through official channels.