

### Product packaging logic diagram

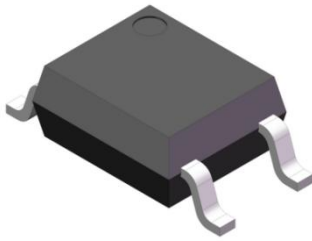

SOP4

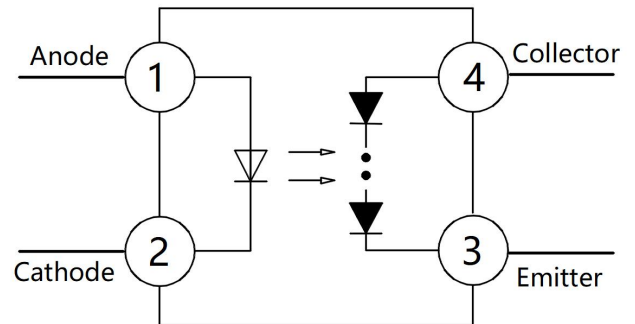

Pin Configuration

### Features

- Open voltage: 7 V (min)
- Short current: 12  $\mu$ A (min)
- High isolation voltage between input and output (Viso =3750V rms )
- Operating Temperature: -55°C~110°C
- Environmentally friendly products, compliant with CQC, UL, and VDE requirements

### Mechanical Data

- Case: SOP4
- Molding Compound: UL Flammability Classification Rating 94V-0
- Terminals: Matte tin-plated leads; solder ability-per MIL-STD-202, Method 208

### Applications

- It is widely used in the feedback control loop of switching power supply and the isolation between the main circuit and the control circuit, ensuring the stability of the output voltage and quickly transmitting the fault signal to trigger the protection mechanism in the case of overload or short circuit.
- In applications such as PLCs (Programmable Logic Controllers), motor drives, and sensor interfaces, it is used for signal isolation to prevent high-voltage noise from interfering with low-voltage control logic.
- For signal isolation in serial communication interfaces (e.g., RS-232,) to improve anti-interference capability.
- Consumer electronics: household appliances, smart home devices (smart lighting, smart sockets), computers and peripherals (printers, monitors), etc.
- Lighting control: AC transistor optocoupler is suitable for dimming control, smart switching, and wireless control, supporting AC input.



### Ordering Information

XL    3906    (X)    (X)    (X) -    (U)    (N)    (Y)  
 ①        ②        ③        ④        ⑤        ⑥        ⑦        ⑧

- ① Brand(XL)
- ② Product series(3906)
- ③ Package type(None:(SOP4))
- ④ Halogen option(None :Halogen free)
- ⑤ CTR Bank (None)
- ⑥ Lead frame (None: Copper)
- ⑦ Customer option 1 (0-9 or A- Z or none)
- ⑧ Customer option 2 (0-9 or A- Z or none)

Part Number	Package	Shipping Quantity	Marking Code
XL3906	SOP4	3000pcs / Tape & Reel	XL3906

### Marking Information

- " XL" denotes brand.
- " 3906" denotes Product series.
- " Y" denotes Year : A(2024), B(2025), C(2026)
- " WW" denotes Week' s number .
- " N" denotes the day of Week.



### Maximum Ratings (@ T<sub>A</sub> = 25°C unless otherwise specified)

Parameter		Symbol	Value	Unit
Input	Forward Current	I <sub>F</sub>	30	mA
	Peak Forward Current **1	I <sub>FM</sub>	1	A
	Reverse Voltage	V <sub>R</sub>	6	V
	Power Dissipation	P <sub>D</sub>	50	mW
Output	Output power dissipation	P <sub>O</sub>	0.5	mW
	Output forward current	I <sub>FD</sub>	50	uA
	Output reverse voltage	V <sub>RD</sub>	10	V

#### Thermal Characteristics

Parameter	Symbol	Value	Unit
Isolation Voltage *2	V <sub>ISO</sub>	3750	V <sub>rms</sub>
Operating Temperature	T <sub>OPR</sub>	-55 ~ +110	°C
Storage Temperature Range	T <sub>STG</sub>	-55 ~ +125	°C
Soldering Temperature *3	T <sub>SOL</sub>	260	°C

#### Notes:

1. Pulse width ≤ 1μs, Duty ratio: 0.001
2. 40 to 60% RH, AC for 1 minute
3. For 10 seconds

#### Electrical Characteristics (@ T<sub>A</sub> = 25°C unless otherwise specified)

Parameter		Symbol	Test Condition	Min.	Typ.	Max.	Unit
Input	Forward Voltage	V <sub>F</sub>	I <sub>F</sub> = 10mA	-	1.3	1.4	V
	Peak Forward Voltage	V <sub>FM</sub>	I <sub>FM</sub> = 0.5A	-	-	3.0	V
	Reverse Current	I <sub>R</sub>	V <sub>R</sub> = 3V	-	-	10	μA
	Input Capacitance	C <sub>in</sub>	V <sub>R</sub> = 0V, f = 1kHz	-	30	-	pF
Output	Trigger LED current	I <sub>FT</sub>	V <sub>OC</sub> > 5V	-	-	3	mA
	Open voltage	V <sub>OC</sub>	I <sub>F</sub> = 10mA,	7	9	-	V
	Short-circuit current	I <sub>SC</sub>	I <sub>F</sub> = 10mA,	12	-	-	μA
	Turn on time	T <sub>on</sub>	I <sub>F</sub> = 10mA, C <sub>L</sub> = 1000 pF	-	0.1	1	ms
	Turn off time	T <sub>off</sub>		-	0.03	1	ms

### Ratings and Characteristics Curves (@ $T_A = 25^\circ\text{C}$ unless otherwise specified)

Fig.1 Forward Current vs. Forward Voltage

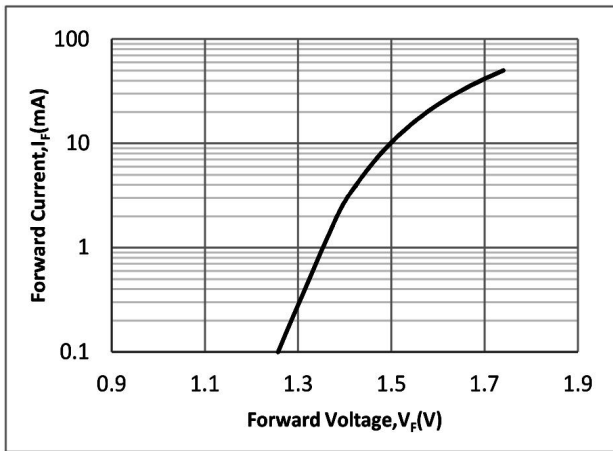

Fig.2 Short-circuit current vs. Open voltage

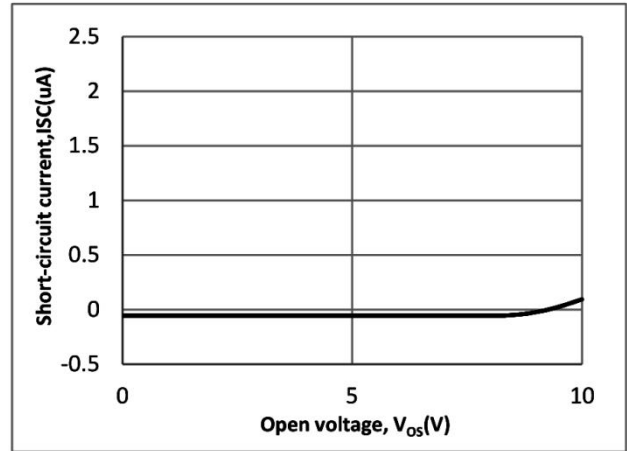

Fig.3 Response Time vs. Load Capacitance

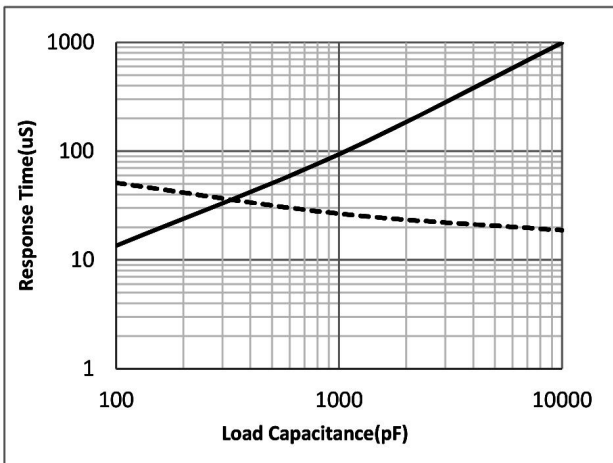

Fig.4 Open voltage vs. Forward Voltage

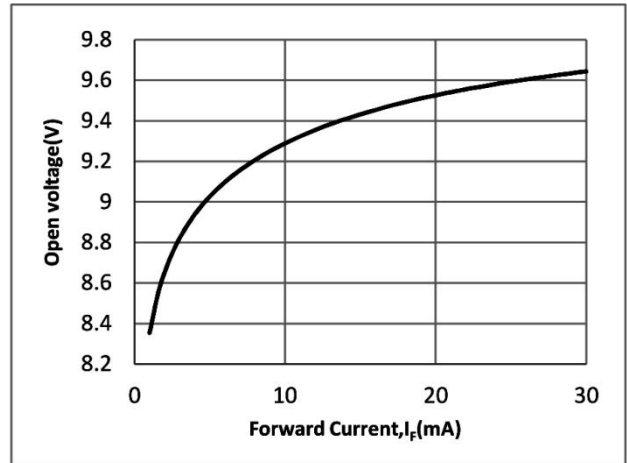

Fig.5 Short-circuit current vs. Forward Current

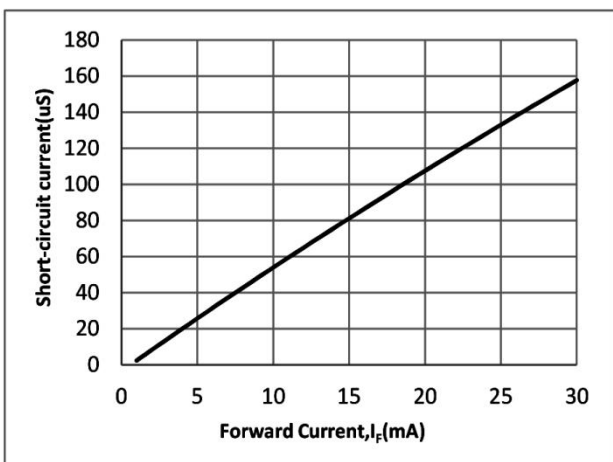
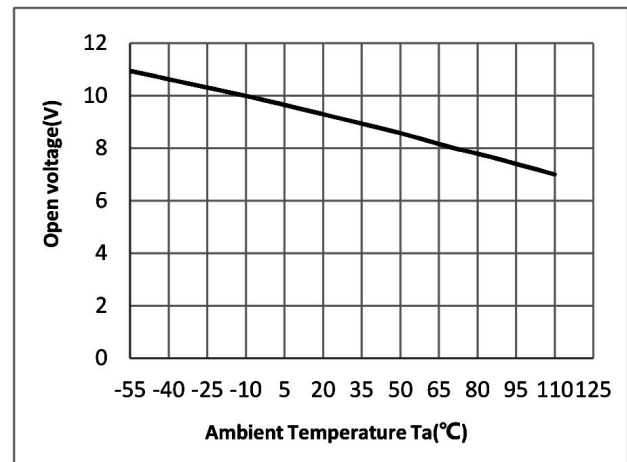

Fig.6 Open voltage vs. Ambient Temperature



**Ratings and Characteristics Curves** (@ T<sub>A</sub> = 25°C unless otherwise specified)

Fig.7 Short-circuit current vs. Ambient Temperature

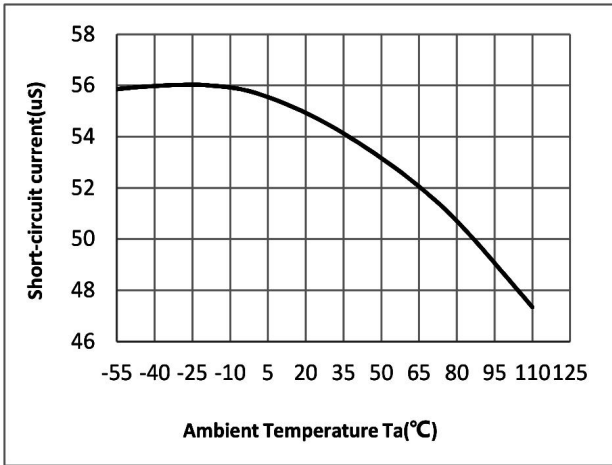

Fig.8 Response Time vs. Ambient Temperature

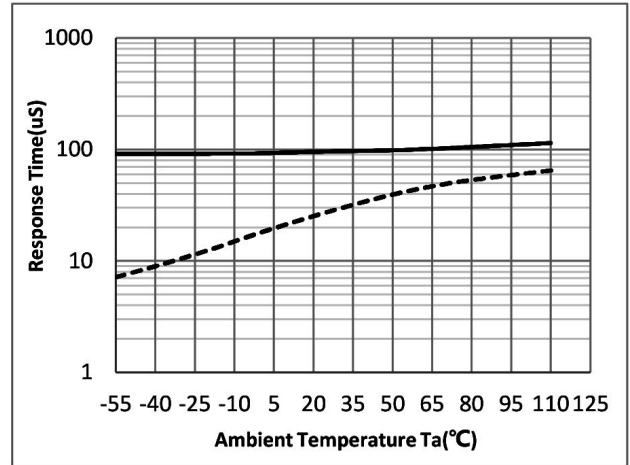
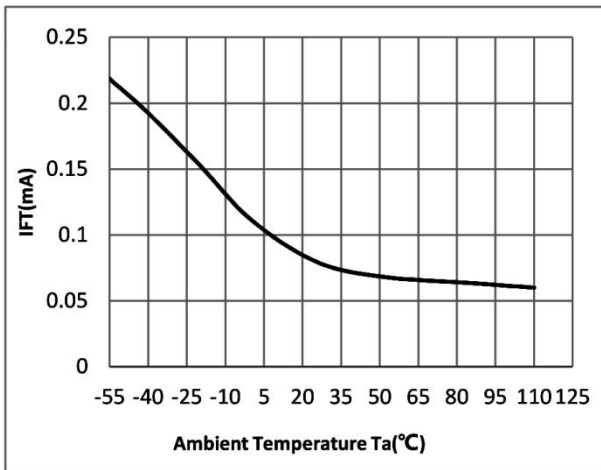
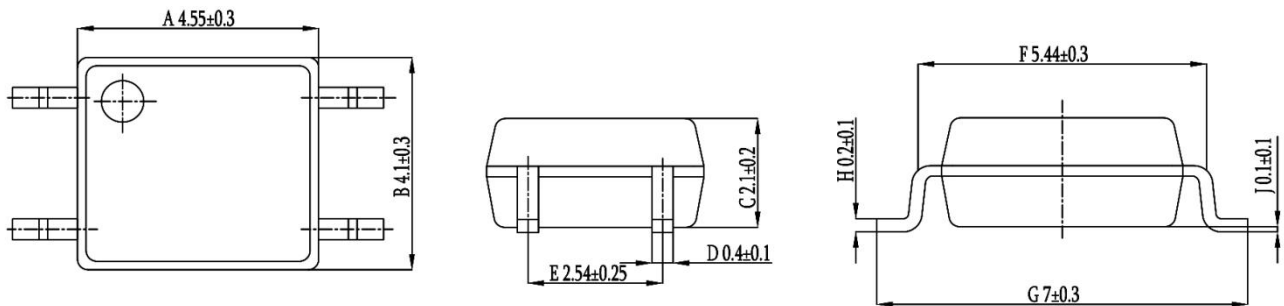

Fig.9 Trigger LED current vs. Ambient Temperature



#### Package Outline Dimensions (unit: mm)

#### SOP4



#### SOLDERING FOOTPRINT (unit: mm)

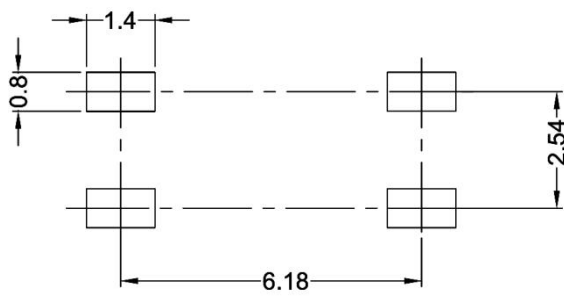

### Reflow soldering

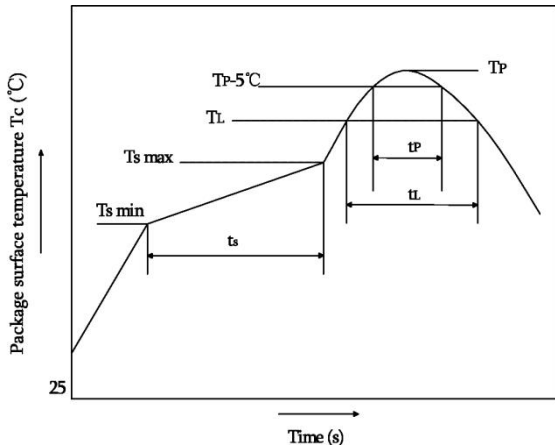

	Symbol	Min	Max	Unit
Preheat temperature	Ts	150	200	°C
Preheat time	ts	60	120	s
Ramp-up rate(T <sub>L</sub> to T <sub>P</sub> )			3	°C/s
Liquidus temperature	T <sub>L</sub>	217		°C
Time above T <sub>L</sub>	t <sub>L</sub>	60	150	s
Peak temperature	T <sub>P</sub>		260	°C
Time during which T <sub>c</sub> is between (T <sub>P</sub> -5) and T <sub>P</sub>	t <sub>p</sub>		30	s
Ramp-down rate(T <sub>P</sub> to T <sub>L</sub> )			6	°C/s

**Note:**

Reflow soldering is recommended at the temperatures and times shown, no more than three times.

### Wave soldering

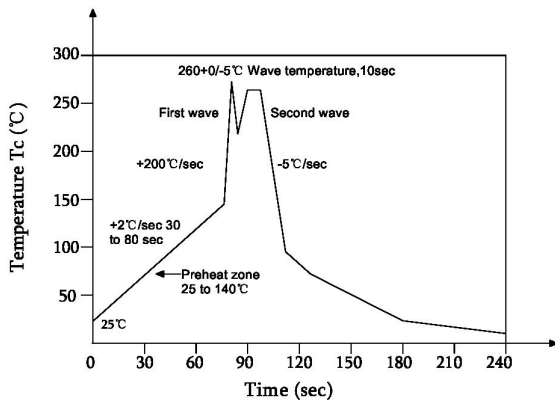

Profile feature	
Average ramp-up rate	~200°C/s
Heating rate during preheat	1°C/s to 2°C/s typical; 4°C/s maximum
Final preheat temperature T <sub>s</sub>	~130°C
Preheat time (25°C to T <sub>s</sub> )	> 60s
Peak temperature T <sub>p</sub>	260°C
Time within peak temperature t <sub>p</sub>	10s
Ramp-down rate	5°C/s maximum

### Soldering with hand soldering iron

- A. Hand soldering iron is only used for product rework or sample testing.
- B. Hand soldering iron requirements: Temperature: 360 °C±5°C within 3s.

### Packing

Package Type	Packing Form	Quantity per Tube & Reel	Quantity per Box	Quantity per Carton	Antistatic Bag Specification	Box Specification	Carton Specification	Note
SOP4	Reel(φ330mm)	3000 pcs/reel	2 reels/box	10 boxes/ctn	380*420mm	350*340*60mm	365*330*370mm	Leave 20 Spaces at the beginning and 50 Spaces at the end

- Summary table

- SOP4 (Reel)

Qty/reel: 3000pcs. Qty/box: 6000pcs.

Qty/ctn: 60000pcs.

Schematic: (unit:mm)

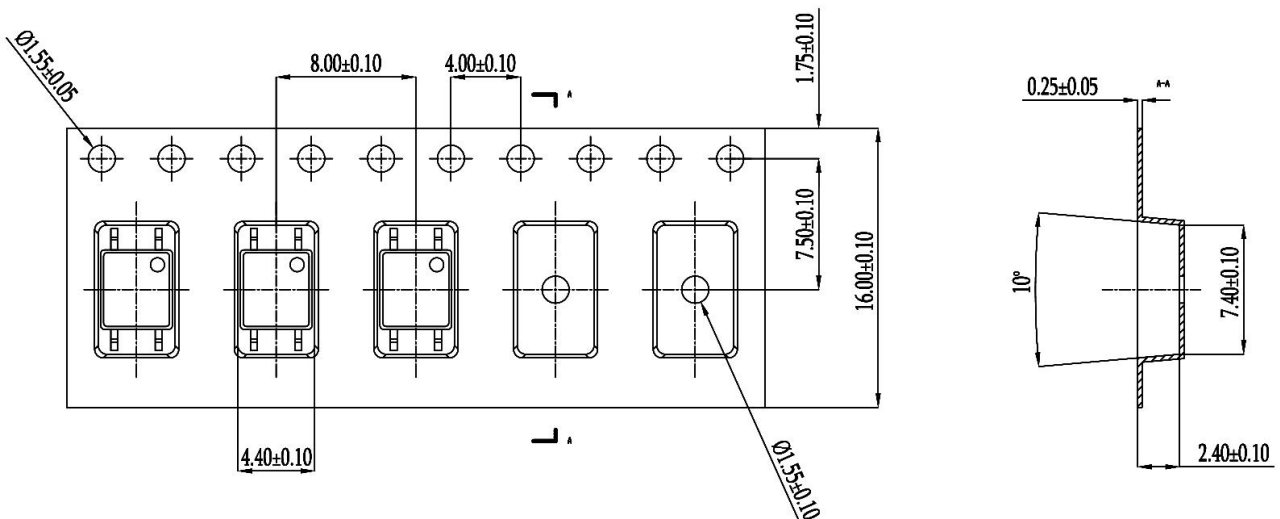

### Attention

- XINGLIGHT implements dynamic technical updates. Specifications are subject to change. Refer to the official website for the latest version.
- Users must strictly adhere to specified conditions. Failures caused by misuse (overload, high temperature, incompatible circuits) are excluded from warranty.
- Contact technical support for customized validation in critical applications (medical devices, industrial control).
- This document is valid until Dec 31, 2026. Updates will be notified on the official website.
- For further clarification on technical specifications or application solutions, please contact us through official channels.