

XL0452, XL0453

Product packaging logic diagram

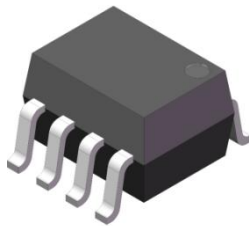

SOP8

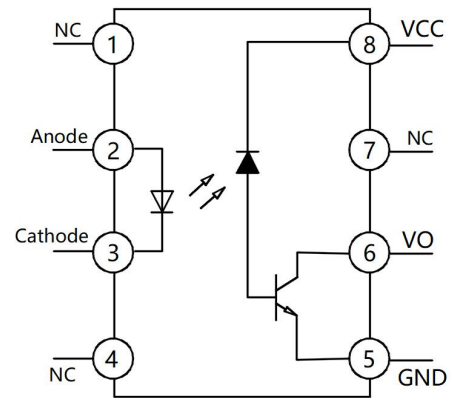

Pin Configuration

Features

- Very high speed: 1MBit/s
- High isolation voltage between input and output ($V_{iso} = 3750V$ rms)
- Operating Temperature: $-40^{\circ}C \sim 100^{\circ}C$
- Environmentally friendly products, compliant with CQC, UL, and VDE requirements

Mechanical Data

- Case: SOP8
- Molding Compound: UL Flammability Classification Rating 94V-0
- Terminals: Matte tin-plated leads; solder ability-per MIL-STD-202, Method 208

Applications

- Widely used in communications and networking, industrial automation and control, motor drive and energy management, medical equipment, and automotive electronics fields.
- Communications and Networking: Fiber optic communication, data center.
- Industrial Automation and Control: PLC and frequency converter, Servo drive system, Industrial robot.
- Motor Drive and Energy Management: Motor control, Motor protection, Power electronics, Consumer Electronics.
- Emerging Technology Fields: Intelligent Transportation System, Medical equipment, Automatic production line.
- Automotive Electronics: In-vehicle Network System, Battery Management System (BMS), EV Charging Station.



Ordering Information

XL 045X (X) (X) (X) - (U) (N) (Y)
 ① ② ③ ④ ⑤ ⑥ ⑦ ⑧

- ① Brand (XL)
- ② Product series (045X)
- ③ Package type(None: SOP8)
- ④ Halogen option (None : Halogen free)
- ⑤ CTR Bank(None)
- ⑥ Lead frame (None: Copper)
- ⑦ Customer option 1 (0-9 or A- Z or none)
- ⑧ Customer option 2 (0-9 or A- Z or none)

Part Number	Package	Shipping Quantity	Marking Code
XL045XP	SOP8	1000pcs / Tape & Reel	XL045X

Marking Information

- " XL" denotes brand
- " 045X" denotes Product series: 2, 3
- " Y" denotes Year : A(2024), B(2025), C(2026)
- " WW" denotes Week' s number
- " N" denotes the day of Week.

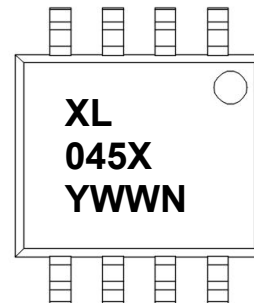

Maximum Ratings (@ T_A = 25°C unless otherwise specified)

Parameter		Symbol	Value	Unit
Input	Forward Current	IF	50	mA
	Reverse Voltage	VR	5	V
	Power Dissipation	PD	45	mW
Output	Collector Output	PO	100	mW
	Output Current	IO	8	mA
	Peak Output Current	IO(peak)	16	mA
	Supply Voltage	VCC	-0.5 ~ 30	V
	Output Voltage	VO	-0.5 ~ 20	V

Thermal Characteristics

Parameter	Symbol	Value	Unit
Isolation Voltage *2	V _{ISO}	3750	V _{rms}
Operating Temperature	T _{OPR}	-40 ~ +100	°C
Storage Temperature Range	T _{STG}	-55 ~ +125	°C
Soldering Temperature *3	T _{SOL}	260	°C

Notes:

1. Pulse width ≤ 1μs, Duty ratio: 0.001
2. 40 to 60% RH, AC for 1 minute
3. For 10 seconds

Electrical Characteristics (@ T_A = 25°C unless otherwise specified)

Parameter		Symbol	Condition	Min	Typ	Max	Unit
Input	Forward Voltage	V _F	I _F = 16mA	-	1.45	1.8	V
	Reverse Breakdown Voltage	B _V R	I _R = 10μA	5	-	-	V
	Temperature coefficient of forward voltage	ΔV _F /ΔT _A	V = 0, f = 1MHz	-	1.9	-	mV/°C
Output	Logic High Output Current	I _{OH}	I _F = 0mA, V _O = V _{CC} = 5.5V, T _A = 25°C	-	0.001	0.5	μA
			I _F = 0mA, V _O = V _{CC} = 15V, T _A = 25°C	-	0.01	1	μA
			I _F = 0mA, V _O = V _{CC} = 15V	-	-	50	μA
	Logic Low Supply Current	I _{CC} L	I _F = 16mA, V _O = Open, V _{CC} = 15V	-	140	200	μA
	Logic High Supply Current	I _{CC} H	I _F = 0mA, V _O = Open, V _{CC} = 15V, T _A = 25°C	-	0.01	1	μA
I _F = 0mA, V _O = Open, V _{CC} = 15V			-	-	2	μA	
Transfer Characteristics	Current Transfer Ratio	CTR	I _F = 16mA, V _O = 0.4V, V _{CC} = 4.5V, T _A = 25°C	19	-	50	%
	Logic Low Output Voltage	V _{OL}	I _F = 16mA, I _O = 3mA, V _{CC} = 4.5V, T _A = 25°C	-	0.18	0.4	V

XL0452, XL0453

Switching Characteristics (@ $T_A = -40^{\circ}\text{C} \sim 85^{\circ}\text{C}$, $V_{CC} = 5\text{V}$, $I_F = 7.5\text{mA}$, unless otherwise specified)

Parameter		Symbol	Condition	Min.	Typ.	Max.	Unit
Propagation Delay Time to Logic Low (Fig.8)	XL0452	TPLH	$R_L = 1.9\text{K}\Omega$, $T_A = 25^{\circ}\text{C}$	-	350	-	ns
	XL0453		$R_L = 1.9\text{K}\Omega$	-	550	-	ns
Propagation Delay Time to Logic High (Fig.8)	XL0452	TPHL	$R_L = 1.9\text{K}\Omega$, $T_A = 25^{\circ}\text{C}$	-	350	-	ns
	XL0453		$R_L = 1.9\text{K}\Omega$	-	550	-	ns
Common Mode Transient Immunity at Logic High (Fig.9)*3	XL0452	CMH	$I_F = 0\text{mA}$, $V_{CM} = 10\text{Vp-p}$, $R_L = 1.9\text{K}\Omega$, $T_A = 25^{\circ}\text{C}$	-	1000	-	$\text{V}/\mu\text{s}$
	XL0453		$I_F = 0\text{mA}$, $V_{CM} = 1500\text{Vp-p}$, $R_L = 1.9\text{K}\Omega$, $T_A = 25^{\circ}\text{C}$	15000	-	-	$\text{V}/\mu\text{s}$
Common Mode Transient Immunity at Logic Low (Fig.9)*3	XL0452	CML	$I_F = 16\text{mA}$, $V_{CM} = 10\text{Vp-p}$, $R_L = 1.9\text{K}\Omega$, $T_A = 25^{\circ}\text{C}$	-	1000	-	$\text{V}/\mu\text{s}$
	XL0453		$I_F = 16\text{mA}$, $V_{CM} = 1500\text{Vp-p}$, $R_L = 1.9\text{K}\Omega$, $T_A = 25^{\circ}\text{C}$	15000	-	-	$\text{V}/\mu\text{s}$

XL0452, XL0453

Ratings and Characteristics Curves (@ $T_A = 25^\circ\text{C}$ unless otherwise specified)

Figure 1. Forward Current vs Forward Voltage

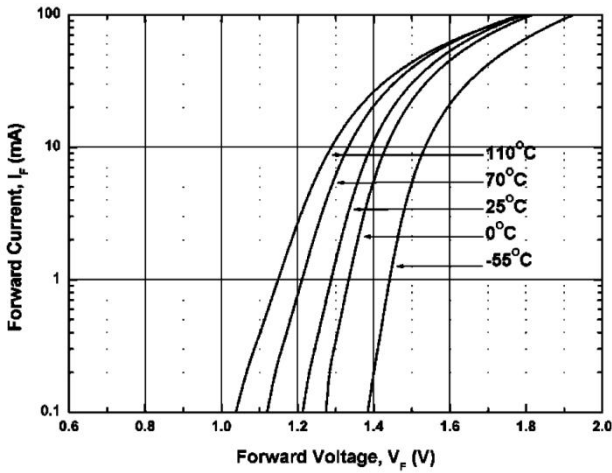

Figure 2. Current Transfer Ratio vs Forward Current

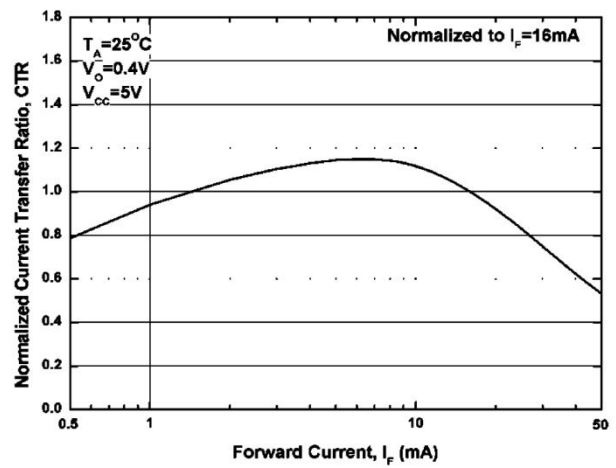

Figure 3. Current Transfer Ratio vs Ambient Temperature

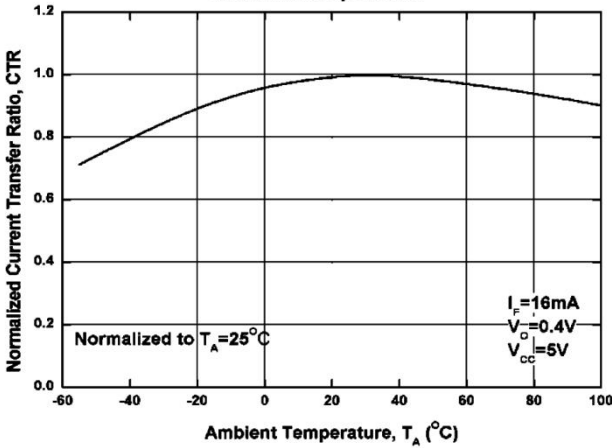

Figure 4. Output Current vs Output Voltage

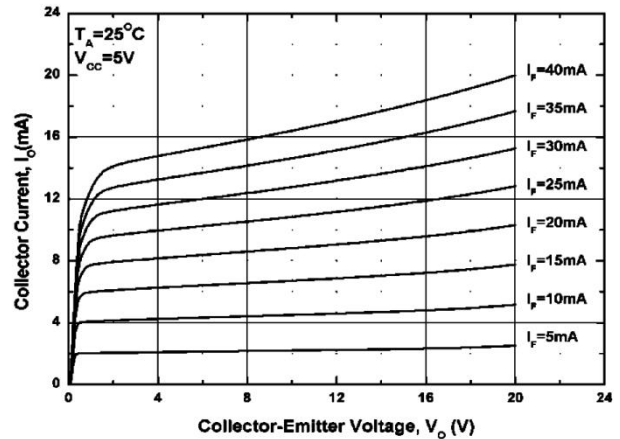

Figure 5. Logic High Output Current vs Ambient Temperature

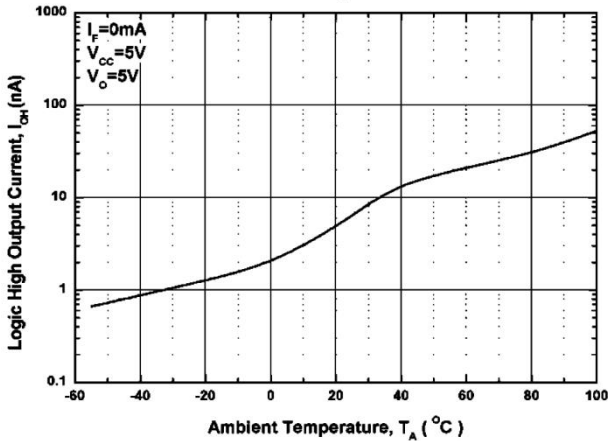
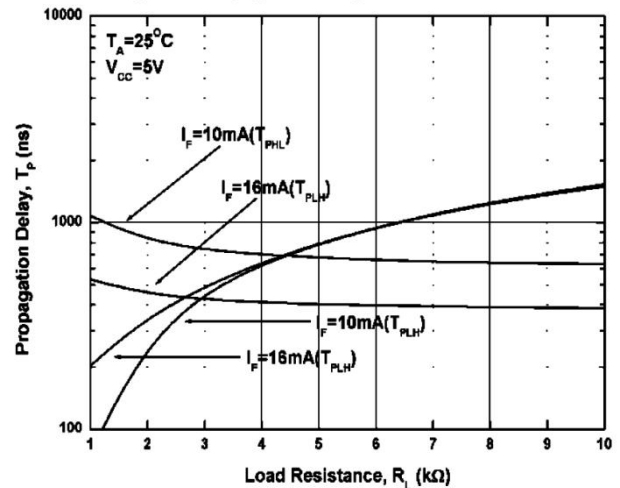

Figure 6. Propagation Delay vs. Load Resistance



Ratings and Characteristics Curves (@ $T_A = 25^\circ\text{C}$ unless otherwise specified)

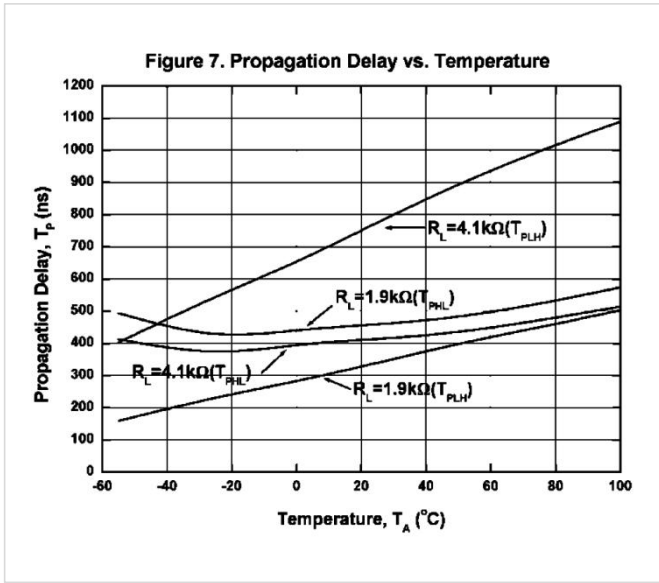

Figure 8 Switching Time Test Circuit & Waveform

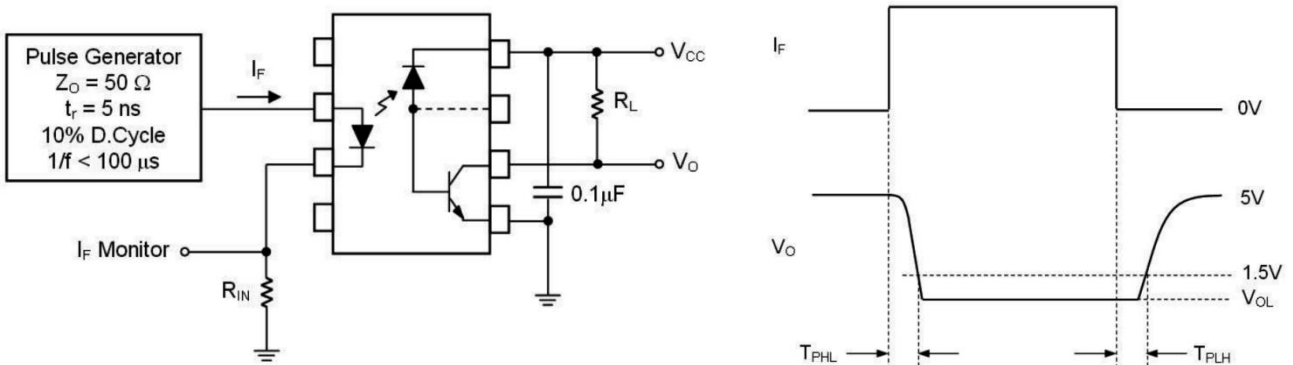
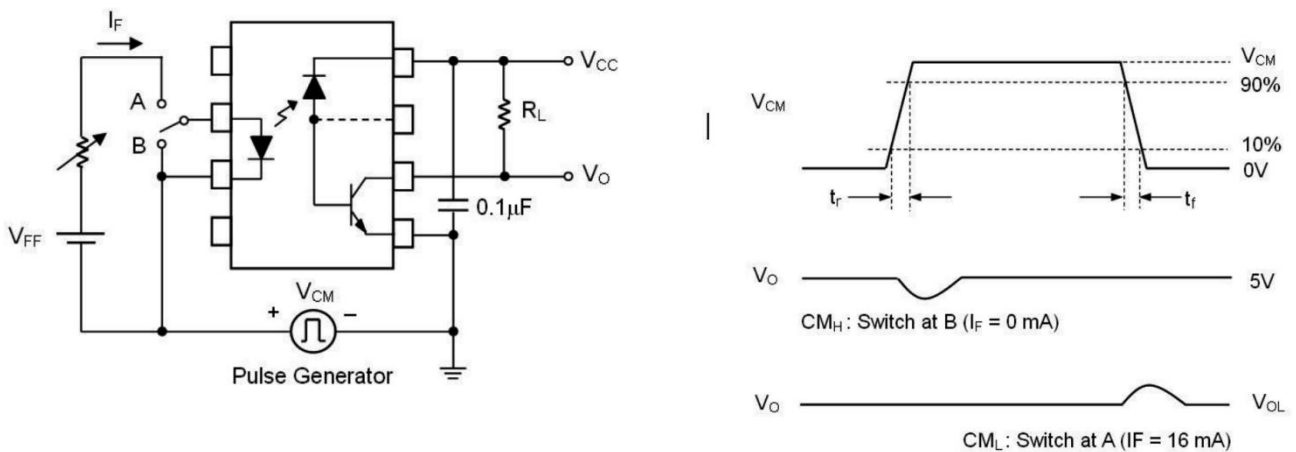
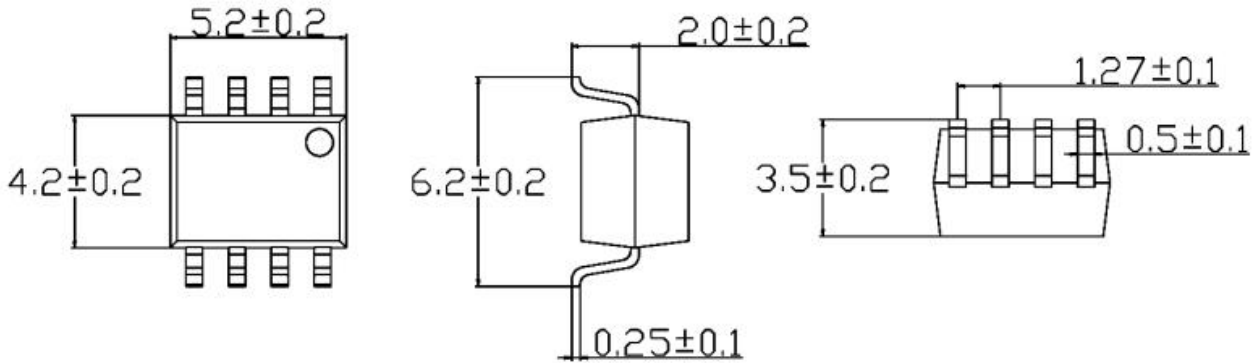

Figure 9 Transient Immunity Test Circuit & Waveform



Package Outline Dimensions (unit: mm)

SOP8



SOLDERING FOOTPRINT (unit: mm)

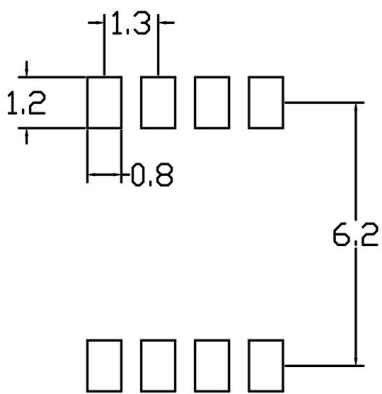

Reflow soldering

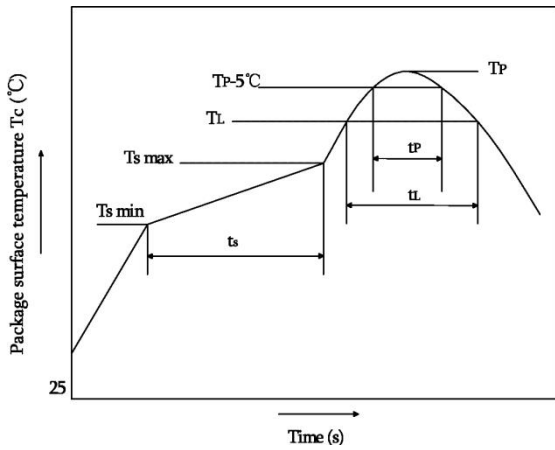

	Symbol	Min	Max	Unit
Preheat temperayure	Ts	150	200	°C
Preheat time	ts	60	120	s
Ramp-up ratea(TL to TP)			3	°C/s
Liquidus temperature	TL	217		°C
Time above TL	tL	60	150	s
Peak temperature	Tp		260	°C
Time during which Tc is between (TP-5) and TP	tP		30	s
Ramp-down rate(TP to TL)			6	°C/s

Note:

Reflow soldering is recommended at the temperatures and times shown, no more than three times.

Wave soldering

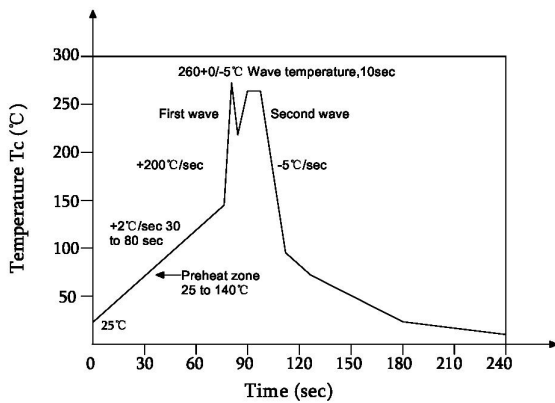

Profile feature	
Average ramp-up rate	~200°C/s
Heating rate during preheat	1°C/s to 2°C/s typical; 4°C/s maximum
Final preheat temperature Ts	~130°C
Preheat time (25°C to Ts)	>60s
Peak temperature Tp	260°C
Time within peak temperature tp	10s
Ramp-down rate	5°C/s maximum

Soldering with hand soldering iron

- A. Hand soldering iron is only used for product rework or sample testing.
- B. Hand soldering iron requirements: Temperature: 360 °C+5°C within 3s.

XL0452, XL0453

Packing

Package Type	Packing Form	Quantity per Tube & Reel	Quantity per Box	Quantity per Carton	Antistatic Bag Specification	Box Specification	Carton Specification	Note
SOP8	Reel (φ330mm Blue)	1000 pcs/reel	2 reels/box	10boxes /ctn	450*390*0.1mm	340*60*340mm	620*360*365mm	Guard band 200mm min.

■ Summary table

■ SOP8 (Reel)

Qty/reel: 1000pcs. Qty/box: 2000pcs.

Qty/ctn: 20000pcs.

Schematic: (unit: mm)

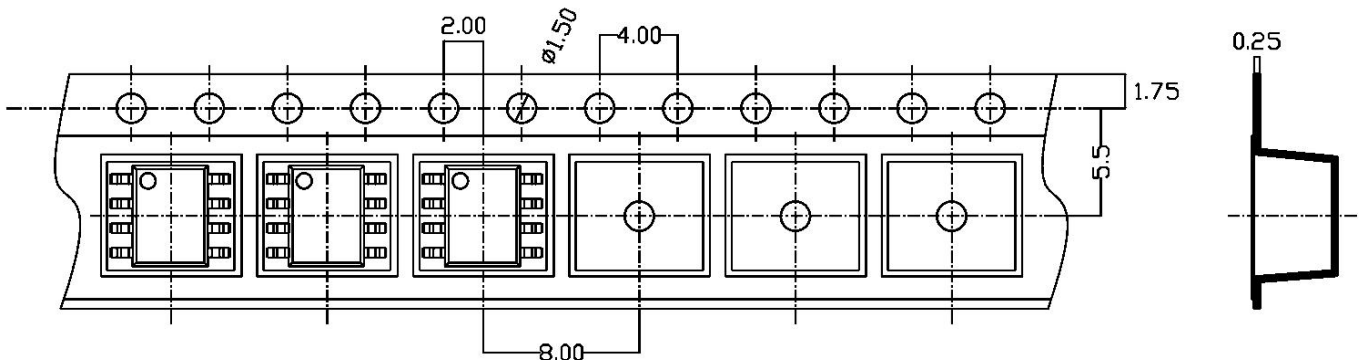
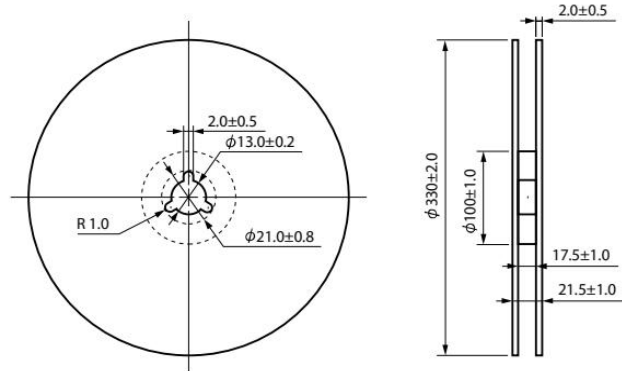

Attention

- XINGLIGHT implements dynamic technical updates. Specifications are subject to change. Refer to the official website for the latest version.
- Users must strictly adhere to specified conditions. Failures caused by misuse (overload, high temperature, incompatible circuits) are excluded from warranty.
- Contact technical support for customized validation in critical applications (medical devices, industrial control).
- This document is valid until Dec 31, 2026. Updates will be notified on the official website.
- For further clarification on technical specifications or application solutions, please contact us through official channels.